

BABY BUOY

Group 22

Fernando Bilbao
Computer Engineer

Harold Grafe
Electrical Engineer

Neysha Irizarry-Cardoza
Computer Engineer

Table of Contents

1.0 Executive Summary	1
2.0 Project Description.....	2
2.1 Motivation.....	2
2.2 Goals & Objectives.....	2
2.3 Related Work	3
2.4 Requirement Specifications	3
2.5 House of Quality.....	3
2.6 Block Diagram	6
3.0 Research.....	8
3.1 Similar Projects.....	8
3.1.1 cFloat Pool System	8
3.1.2 SafeFamilyLife by SafetyTech Pool Alarm.....	9
3.2 Mobile Application Development.....	9
3.2.1 iOS VS Android Application.....	10
3.2.3 Wireless Communication Methods.....	11
3.3 Microcontroller	15
3.3.1 Microcontroller Options.....	15
3.3.2 Microcontroller Board Comparisons	18
3.3.3 Microcontroller Choice.....	21
3.4 Battery.....	23
3.4.1 Battery Types and Applications.....	23
3.4.2 Battery Choice	25
3.5 Alarm System.....	25
3.5.1 Piezo Buzzer	25
3.6 Image Processing	26
3.7 Computer Vision.....	28
3.8 Solar Cell	30
3.9. Voltage Regulation	31
3.10 Two-Step Verification	34
3.10.1 Raspberry Pi Camera v2	34
3.10.2 MMA8451.....	35
3.10.3 Passive Infrared Sensor.....	35
3.10.4 AMG8833	36
3.11 Software Utilities	37
3.11.1 Staying Connected	37
3.11.2 Development Tools.....	38
3.12 Pulse Width Modulation	40
3.13 Printed Circuit Board	41
3.13.1 PCB Partitioning.....	44
4.0 Design Constraints and Standards	46
4.1 Constraints	46
4.1.1 Economic Constraints	46
4.1.2 Health and Safety Constraints.....	46

4.1.3 Social Constraints	47
4.1.4 Sustainability Constraints	47
4.1.5 Time Constraints	48
4.1.6 Presentation Constraints.....	48
4.1.7 Manufacturability Constraints	49
4.2 Standards.....	49
4.2.1 IPC PCB Standards	49
4.2.2 IEC 60950-1	51
4.2.3 IEC 60529	51
4.2.4 Frequency Band Standards	53
4.2.5 Lead Solder Safety	54
4.2.6 RoHS Compliance	56
5.0 Design	58
5.1 Hardware Design	58
5.2 Battery Selection.....	61
5.3 Electrical Design.....	62
5.3.1 Electrical Schematic.....	65
5.4 Software Design.....	68
5.4.1 Software Class Diagram	68
5.4.2 MCU Software Interaction.....	70
5.4.3 User Interface (UI).....	71
6.0 Project Testing and Prototype	73
6.1 Testing.....	73
6.1.1 Hardware Testing.....	73
6.1.2 Software Testing	82
6.2 Prototyping.....	84
7.0 Administrative Content.....	87
7.1 Project Budget/financing	87
7.2 Initial Project Milestones	88
8.0 Conclusion	90
Appendix A References	91
Appendix B Permissions.....	93

Figure of Figures

Figure 1: House of Quality trade-off table.....	5
Figure 2: Project Block Diagram	6
Figure 3: cFloat pool alarm system [1].....	8
Figure 4: SafeFamilyLife pool alarm system [2].....	9
Figure 5: Wireless Communication through Bluetooth Model.....	12
Figure 6: Wireless Communication through Wi-Fi Model.....	12
Figure 7: ESP8266 [3]	14
Figure 8: ESP32 [4]	14
Figure 9: ATWINC1500 [5]	14
Figure 10: Piezo Buzzer [6]	26
Figure 11: Image Processing Data Exhibition [7].....	27
Figure 12: Computer Vision-Edge Detection	28
Figure 13: Photovoltaic cell technology.	31
Figure 14: Basic linear voltage regulator with bypass capacitors.....	32
Figure 15: Buck Converter.....	33
Figure 16: Boost Converter.....	33
Figure 17: Buck & Boost Converter	34
Figure 18: PIR Sensor [8]	36
Figure 19: AMG8833 Camera Module [9]	37
Figure 20: Duty Cycle examples.....	41
Figure 21: PCB layers.	42
Figure 22: IPC Standards [10]	50
Figure 23: IP Rating Chart [11]	52
Figure 24: Articulated arm produced by CAMVATE.	58
Figure 25: PVC Window holder	59
Figure 26: Main housing body and caps.	59
Figure 27: Cable Gland [12]	60
Figure 28: The Baby Buoy full assembly.	60
Figure 29: 5000 mAh 3.7V Li-Po battery used. [13].....	61
Figure 30: AMX3d 165mm x 135 mm 6.0V 600mA solar cell.....	62
Figure 31: 1N5822 Schottky diodes	63
Figure 32: Solar cell voltage higher than battery voltage.	64
Figure 33: Battery voltage greater than solar cell voltage.	64
Figure 34: Electrical system layout.....	65
Figure 35: Schematic diagram	66
Figure 36: Basic Class Diagram of Software.....	68
Figure 37: High-Level Class Diagram of Software	69
Figure 38: Microcontroller Software Diagram	70
Figure 39: UI Prototype	71
Figure 40: Wi-Fi Setup	73
Figure 41: Wi-Fi Testing	74
Figure 42: Thermistor Test	74
Figure 43: Pixel Test.....	75
Figure 44: Solar Cell Test with multimeter	75

Figure 45: Solar Cell Test regular setup	76
Figure 46: Solar Cell Test aiming cells at the sun	76
Figure 47: Battery Charger Wiring	77
Figure 48: Battery charger output current.....	78
Figure 49: Battery charger output current.....	78
Figure 50: Testing temperature sensor.....	79
Figure 51: Testing PIR sensor.....	80
Figure 52 PIR Sensor Readings	80
Figure 53: Testing Piezo Buzzer.....	81
Figure 54: Testing MCU.....	81
Figure 55: MCU LED Test	82
Figure 56: cFlout Permission Request	93
Figure 57: SafeFamilyLife pool alarm system Permission.....	94
Figure 58: ESP32, ESP8266, ATWINC1500, PIR Sensor, AMG8833 Camera Module.	95
Figure 59: Piezo Buzzer Permission	96
Figure 60: Image Processing Data Exhibition User Rights	97
Figure 61: IPC Standards Permission	98
Figure 62: IP Rating Chart Permission	99
Figure 63: Cable Gland, 5000mAh 3.7V Li-Po battery used Permission.....	100

List of Tables

Table 1: Wi-Fi Comparison Table	14
Table 2: Microcontroller Boards and Microchips Specifications Comparison	22
Table 3: Battery Comparison	25
Table 4: Guidelines for trace current capacity. Source: Armisted Technologies	44
Table 5: Theoretical vs Actual Distance and Internet Speeds with 2.4 GHz frequency...	53
Table 6: Theoretical vs Actual Distance and Internet Speeds with 5 GHz frequency.....	54

1.0 Executive Summary

Throughout the United States, drowning is the number two cause of death among children between the ages of 1-4. According to the Center for Disease Control, approximately 800 children drown every year throughout the United States. Most of those drownings occur in our very own backyard swimming pools. Four main components that influence this death toll include failure to wear life jackets, lack of swimming capabilities, lack of supervision and lack of barriers to prevent water access while unsupervised.

In today's market, there are numerous devices to aid parents in need of extra pool safety and or supervision. One of these devices is the pool alarm. Most of these devices have a loud alarm that goes off once it detects large ripples of water from a child falling into the pool. However, there are some disadvantages based on user reviews, including short lifespan of some devices and the sensitivity of the motion sensor being too high. It is observed that the lifespan of most of these devices is limited from a few weeks to a few months before they begin to break down or stop functioning. Also, some users report many false alarms that may be provoked from filter pumps, wind, and small animals.

In our project, we would like to construct a “buoy” like device that may counter these disadvantages and overall be more efficient for those investing in pool alarm systems. Our device would include features such as a sounding alarm to alert individuals that there may be trouble in the swimming pool. Also, a mobile application that would be connected through WiFi to inform parents if they happen to be far from the reach of the sounding alarm. The mobile application would also contain information such as logs from when the motion was detected, and device battery life. Our buoy device will be equipped with a water surface sensor. To maintain and sustain battery life, we will enforce solar capability to convert light into energy. We would also implement a two-step verification using underwater visuals, to reduce any false alarms from filters, wind, or any other miscellaneous objects that might disturb the surface of the water. This underwater vision may be implemented by having a waterproof camera attached to a rotating arm or using a 360 camera, to scan to the bottom of the water.

One of the critical features of our buoy device is a first encounter verification. This will be implemented with an efficient surface sensor to detect motion surrounding the pool top. This may be implemented using a 360 Camera or having a camera mounted on a rotating arm. This is crucial to perfect as it would send an alert to parents before the child curiously wonders too far off the edge of the swimming pool.

A pool alarm is crucial to have if you are a parent of adventure-seeking children between the ages of 1-4. Swimming pools are great fun in the backyard but they also pose a threat to those too young to know the difference between life and death.

2.0 Project Description

The following section is written to illustrate the motivation as well as the goals and objectives of pursuing this project. The dangers of having a swimming pool, specifically in the state of Florida, will be highlighted to allow the reader to better understand our concerns and the overall concept behind investing in a pool alarm. Lastly, an overview of the projects requirement specifications to complement the goals and objectives will be present in the following passage.

2.1 Motivation

In the sunshine state of Florida, it is always summertime. Having approximately 392,048 swimming pools throughout the state; scattered between civilian homes and community clubhouses, Florida holds second place in the nation with the most amount of swimming pools. Nevertheless, Florida takes lead in the nation for the number of child fatalities due to drowning. According to the USA Swimming Foundation, in 2017, there was a total of 51 children that passed away due to drowning in pools or spas. This was a 20 percent increase from the figures that were analyzed in the previous year, 2016. Based on the profiles recorded by the USA Swimming Foundation, 80 percent of those fatalities involved children between the ages of 1-4, and 20 percent being kids 15 and younger.

Our goal with this project is to construct a buoy with sensors to alert any parent that may have curious children that roam near the pool if or when they take a harmful, unsupervised step into the pool. The main objective of this project is to reduce the number of child fatalities that occur every year in the sunshine state of Florida.

2.2 Goals & Objectives

- The system shall have border mounting capabilities, as well as, waterproof technology or seals that will allow it to function when submerged in water.
- The system shall have a long-lasting battery
- The system shall have Wi-Fi capabilities to be able to connect to multiple devices that are operating in the mobile application.
- The device shall be audible, producing a very loud noise to alert those around the area there is trouble.
- The system shall have solar power capabilities, to sustain and elongate battery life.
- The system shall have an accurate camera and motion sensing devices installed. Keeping the probability of a false alarm very minimal.
- The device shall be cost-competitive, making safety our number one concern rather than adding excessive amounts of features the drive up the cost. This will also be pleasing to the parents.

2.3 Related Work

Currently, there is a company by the name of “cFloat” that has a pool system with similar features. However, based on multiple user reviews, it is reported that the device is too technical, not very user-friendly and not worth the cost. The main goal for our device is to maintain a safe environment for children around the swimming pool. Our vision is to keep everything user-friendly, cost-competitive and not too technical that it strays away from the general purpose.

2.4 Requirement Specifications

- Motion Detection to sense water breaches
 - PIR Sensor
 - Up to 10 meters
- One streamable cameras for visual verification.
 - Camera will be for underwater visuals.
 - Will be capable of object recognition and image processing.
- Wireless communication to connect with a mobile application and housing units.
 - This will be accomplished through Wi-Fi connectivity
 - Which may reach up to 300 feet from the actual unit.
- Portable, Self-Contained and Light Weight
 - Up to 10 pounds
 - Easy installation
- Audible alarm capability of up to 90 dB, for both outdoor device and home units
- Housing will be durable and waterproof
- Electronic devices will be sustainable to large heat indexes.
- Solar Power capabilities to sustain battery life
- Worry-free battery life
 - 1 day between charging

2.5 House of Quality

The marketing requirements of the Baby Buoy will include reliability, durability, ease of use, battery life, compactness, and cost. The design will focus on increasing all the requirements except cost, which will be minimized whenever possible. The engineering requirements include water proofing, power consumption, WiFi range, dimensions, redundancies, and cost. The Baby Buoy will be partially submerged in water, therefore the device must be waterproof to ensure a long life and reliable operation. Since the device will be self-powered by solar energy stored in a battery pack, power consumption must be minimized. Pools are usually outdoors and relatively far from household routers, therefore the WiFi range of the Baby Buoy must be maximized to ensure data transmission is uninterrupted. The device must be portable and easily put away when the alarm system is not needed, for this reason the dimensions are minimized as much as possible. The design will increase

redundancies to prevent false alarms from wasting battery power and the user's time. Finally, cost will be minimized to keep the device competitive in the market.

Waterproofing the device will increase reliability and durability but will negatively affect cost. Since the device housing will be tightly sealed, the WiFi range will also be negatively affected. Decreasing power consumption will positively affect the battery life and it will require smaller solar cells and battery capacity which will reduce the cost. However, it will have negative impacts on redundancies and WiFi range. Redundant systems require power to operate, decreasing the power will limit the use of these systems. Increasing WiFi range will increase reliability and ease of use but will also increase cost which should be minimized. Reducing the device dimensions will increase compactness but will have negative effects on battery life, redundancies, and cost. Since the available space is smaller, more compact and expensive batteries must be used and less area for redundant systems. Reducing cost will negatively affect all aspects of the design except power consumption.

The targets for engineering requirements were selected as follows: IP58 is the Ingress Protection rating for dust protection and resistance to temporary submersion in water. Water resistance can be demonstrated by submerging the buoy in water for several seconds and inspecting it for leakage. A 5 W power consumption is comparable to WiFi enabled wireless security cameras in the market today. The power consumption can be measured over time to confirm the specification has been met. Depending on the battery capacity selected, the power consumption can be calculated by how long it takes drain the battery. A 115 ft WiFi range is a common distance for current household routers. The Baby Buoy can be gradually moved farther away from a wireless receiver until data is unable to be transmitted, then that distance can be measured to find the WiFi range. The dimensions are flexible, as they may change through the design process, 20"x 8"x 4" is a sensible, non-intrusive size for a pool accessory. The dimensions can be demonstrated with a measuring tape during the presentation of the project. Two-factor verification is part of the design, an above water IR sensor system will sense the motion of potential targets and the underwater camera will verify the object being tracked has been submerged. This specification can be demonstrated by tracking a baby doll as it drops into a small pool. Finally, the target price of \$250 places the product at the higher end of the market for similar products. The price requirement can be demonstrated by divulging the cost of each component used in the device.

The house of quality diagram shown in Figure 1 summarizes the relationships between marketing and engineering requirements. It also shows the effect each engineering requirement has on the others. One arrow pointing up represents a positive correlation while an arrow pointing down is a negative correlation. Double arrows in either direction represent stronger effects on those requirements. The plus and minus signs next to each requirement determines whether the design will try to maximize or minimize that requirement. Marketing requirements are shown horizontally in green while engineering requirements are vertical in a tan color.

Finally, Targets for engineering requirements are shown vertically at the bottom in blue, aligned with their respective engineering requirements.

		Water Proofing	Power Consumption	WiFi Range	Dimensions	Redundancies	Cost
		+	-	+	-	+	-
1) Reliable	+	↑		↑↑		↑↑	↓↓
2) Durable	+	↑↑				↑	↓↓
3) Compact	+		↑	↓	↑↑	↓	↓
4) Ease of Use	+			↑			
5) Battery Life	+		↑↑	↓	↓	↓	↓
6) Cost	-	↓		↓	↓	↓	↑↑
Targets for Engineering Requirements		IP58	≤ 5W at max load	≤ 115 ft	20" x 8" x 4"	2 factor verification	≤ \$250

Figure 1: House of Quality trade-off table

2.6 Block Diagram

The following is the block diagram for the baby buoy. The PIR sensor will detect if a object with heat has fallen into the water. If it is a positive reading, then it will trigger the IR camera to detect what type of object is in the water. If there is a positive reading, then the user will be alerted via their phone, while also having a sounding physical alarm on the system. The WiFi module will allow the microcontroller to communicate with the users phone via a mobile application. When a positive alarm is triggered, the user will be notified via the mobile application. The user can configure their buoy settings via the mobile application, such as turning the alarm on or off when the system is triggered. If a reading is incorrect, then the user will not be notified. The battery will be supply power to the whole Baby Buoy system, while also providing solar charging capabilities via solar panels.

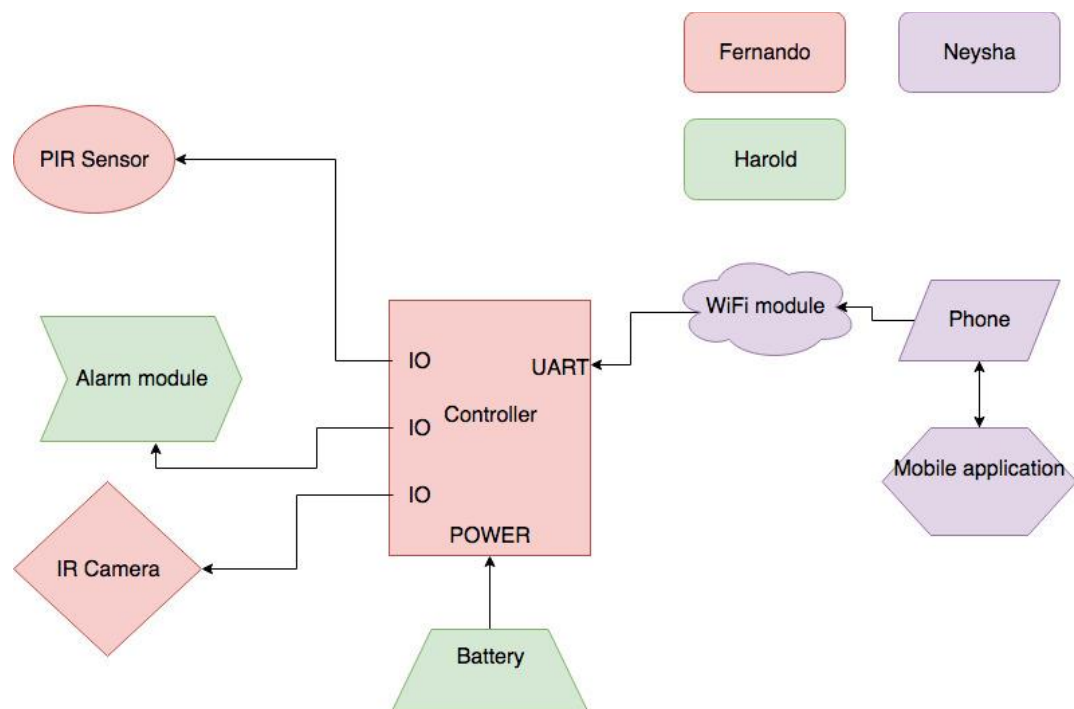

Figure 2: Project Block Diagram

Block status:

- IR Camera: Acquired
- Alarm module: Acquired
- PIR Sensor: Acquired
- Controller: Acquired
- WiFi module: To be acquired
- Phone: Acquired
- Mobile application: To be acquired
- Battery: Acquired

Diagram Legend:

IR Camera: Secondary system to provide visuals of an object falling into the water.

Alarm module: Component that creates a sound if a correct object has been detected.

PIR Sensor: System that detects motion above the water.

Microcontroller: Controller that interacts with all the components.

WiFi module: Controller communicates with the user using wireless internet.

Phone: User device needed for a mobile application.

Mobile application: Application needed to confirm if an object has fallen in the water.

Battery: Component that powers everything up.

3.0 Research

The following section will dive into examining various ways of accomplishing the requirements and specifications of our product. This is being done through extensive research in the implementation of software and hardware components. There will be an examination on existing products with similar functions or appearance as that, that is envisioned in our baby buoy. Furthermore, comparison and considerations of various devices, framework, and material that may seem fit to be implemented on the baby buoy.

3.1 Similar Projects

This section is a deep dive into some existing products and their architectural design and implementation, that will influence the style/design of the baby buoy.

3.1.1 cFloat Pool System

This product demonstrates several key components that will be achieved in our final baby buoy product. Some features to take away from this item would be the mobile device connectivity. The cFloat is capable of connecting to cell phones and tablets of any carrier through the users Wi-Fi network. Within the mobile application users can interface with the device, and display data such as water temperature, pH levels, battery life, etc. that is being collected from the cFloat. The device also contains a motion sensor that will keep an eye out for any motion that is being detected from the surface of the pool. Unfortunately, the device itself does not have an audio alarm built into the actual cFloat, but it comes with a separate “home” unit that is rechargeable through a micro-USB port. This “home” unit is also connected to the Wi-Fi of the user as well as cFloat, so that it may activate and set an alarm that will amplify through the house if there is ever any danger in the pool.



Figure 3: cFloat pool alarm system [1]

Some key features that can be taken away from the cFloat are its Wi-Fi connectivity through multiple devices. For the Baby Buoy, there will be a mobile application that will be able to collect data from the device out in the pool at a range of up to 300 feet. Some of

the information that the baby buoy will capture information from the temperature sensor, as well as motion from multiple cameras. Through its Wi-Fi connection, the Baby Buoy will also be able to send a signal to a home unit that will amplify the alarm once it is set. All these sensors will be monitored through the mobile application, just like that of the cFloat. The cFloat system costs \$399 via the PoolWarehouse website.

3.1.2 SafeFamilyLife by SafetyTech Pool Alarm

This product is simplistic in design but has a powerful delivery. The SafeFamilyLife pool alarm has mounting capabilities on any border of the pool's edge. Made of plastic, it is capable of keeping all electronic components inside the housing dry, making it waterproof. Another feature that the SafeFamilyLife has is an alarm that is built into the unit itself. This alarm is set off once there is any detection of a water level change, like that of someone falling into the pool. This sensor may be adjusted based on the level of the water.

Some key features that will be reflected on the Baby Buoy are its capability of having the device mounted on the border of the pool. This is going to be implemented by using sandbags as the Baby Buoy team would like to construct a device that is mobile. A waterproof housing will be crucial to making sure none of the electrical components get damaged, such as the MCU and the cameras. An in-house alarm will be installed as well just like that of the SafeFamilyLife pool alarm. The SafeFamilyLife pool alarm costs \$139.99 via Amazon. The figure below shows the SafeFamilyLife pool alarm product.



Figure 4: SafeFamilyLife pool alarm system [2]

3.2 Mobile Application Development

The following section will break apart the differences between iOS and Android applications. Research on mobile application development will be conducted on which is the best programming languages, based on the platform. A detailed description of the UI

of the mobile application along with expected widgets that would be interactive with the Baby Buoy.

3.2.1 iOS VS Android Application

In this section research on the very much debated topic of Android versus iOS development, will be crunched down and analyzed to what would be best fit for the Baby Buoy project. Analyzation on both platforms will range from the user interface (UI), different mobile device compatibility, programming language, and longevity of publishment on the devices store.

3.2.1.1 iOS Platform

Mobile application development for iOS has its pros and cons. One of the biggest highlighted pros comes from how user-friendly applications developed for iOS are. Based on multiple user reviews, the App Store for iOS is very aggressive when it comes to choosing what apps may be showcased in their store. This is due to iOS being a closed platform, where Apple designs all of their software and hardware. One of their guidelines is creating having a “user-friendly” interface for everyone, something that is appealing, attractive to the eye and easy to get around. Which leads to a con, the app store is very strict with applications that are attempting to be published onto the actual App Store. This results in many rejections. Throughout the years many users have been able to find a suitable framework to reduce the number of rejects, by having the framework already set to fit a large majority of the needs that the App Store looks for in their published applications. Due to the fact they have only a limited amount of apps that make it to the App Store, must app are able to load up fairly quickly and run smoothly without any lag or long wait times. Most submitted mobile applications get evaluated within four to five days before getting a notification on the status of the app.

A great feature about iOS development is that there are only 20 different types of mobile devices that are compatible with the iOS platform. This limited amount of devices gives developers a shorter development process being that they consider dimensions from only the 20 different mobile devices. iOS uses a programming language called Swift, which is created to handle Apple’s framework. Taking on the preexisting framework of apple, swift is practically identical from that of objective C. Apple first started development using the objective C language but has advanced to create its own type of programming language as time has passed.

The likelihood that the Baby Buoy team will be implementing an app on the iOS platform is not high. Due to the lack of objective C knowledge, aggressive and strict regulations on new apps, and wait time for application approval, iOS seems to be less fit for the Baby Buoy project.

3.2.1.2 Android Platform

Android application development is much more popular based on the number of different devices that can support these applications. Developing for the Android platform can be

rather challenging. The Android platform is an open source software that allows developers to extend to the furthest depth of their imagination when it comes to creating an application. An open-source platform allows flexibility, custom frameworks, and freedom to have full creative power over the functionality and features of the application. Although, from the large number of mobile devices that can sustain the Android operating system it suffers from fragmentation, which leads to having a different user experience from device to device. This is very challenging to the Android app developer, as they must optimize per individual operating system and screen dimensions, thus driving up cost in development. A great perk about having an open source software is that there are limited regulations that developer must adhere by. This creates a great turn over when it comes to launching and publishing an app on the Google Play Store. The wait time for must submitted mobile applications ranges from 30 minutes to five hours, to receive an acceptance or rejection. The Android platforms utilize Java as its programming language for all app development.

The Baby Buoy team will be developing its mobile application for use on Android devices, for these reasons: The programming language, Java is a more universal language that has derived much of its syntax from C and C++, two languages that the team is more familiar with. Having the ability to submit an application into the Google Play Store for evaluation and having it evaluated in less than five hours is a great advantage. This will allow more time to fix and or update the app so that it may be published properly on the Google Play Store. Although the team will deal with optimizing for several different devices, that would be a small price to pay to have the flexibility to be creative and construct a mobile application that would be most suitable for our users' needs.

3.2.3 Wireless Communication Methods

There are numerous ways of accomplishing wireless communication between multiple devices. Wireless communication has taken lead in the past few years, having multiple types of information travel through waves, rather than through cables. In the following subsection, a detailed description will be made between the two most popular ways of wireless communication, Bluetooth and Wi-Fi. These two forms of communication will be broken down to evaluate which would be the better form to take on in the construction of the Baby Buoy.

3.2.3.1 Bluetooth

Bluetooth connectivity can be seen in devices such as headphones, keyboards, automobiles, and a few other small day-to-day devices. It operates at 2.4GH with a low bandwidth of 800Kbps. This is great when it comes to pairing perhaps, one or two devices at a time but it will eat up its bandwidth when it's paired with more than that. This will take a toll on the performance and create lag on any information that is being transmitted between all the devices. With that in mind, with the low bandwidth and frequency, Bluetooth will tolerate a range from five to 30 meters between the main device and the connected consoles. Although Bluetooth may not be very compatible with a large range or connectivity of many devices in a single moment, it's very cost effective. Bluetooth is very power friendly, drawing as little as 2.5mW and at most 10mW. This power consumption is determined

based on the device your Bluetooth is paired with. Large devices like a speaker with an amp would draw more power in comparison to a wireless headphone.

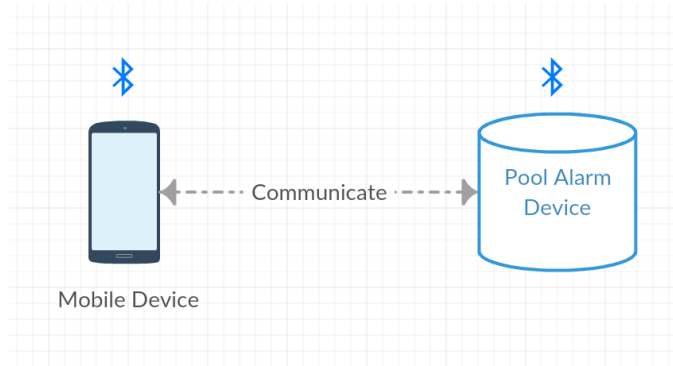

Figure 5: Wireless Communication through Bluetooth Model

Microcontroller boards such as the Raspberry Pi Model B come equipped with Bluetooth capabilities. This is very convenient in the perspective of a low startup cost when developing the design of your device.

3.2.3.2 Wi-Fi

Wi-Fi operates via radio frequencies very much like Bluetooth but one of the biggest differences is how large the range of use is for Wi-Fi. Wi-Fi can operate as far as 300 feet. Depending on the Wi-Fi network that the user may have, its frequency can take up to 60 GHz bands. This is great to be able to receive and send information very quickly. With such a large frequency tolerance, Wi-Fi also has a high bandwidth ability of approximately 11 Mbps. With so much bandwidth, the user may also connect numerous devices at the same time with no lag or performance loss. Wi-Fi compatibility is seen through gadgets such as Desktops, Laptops, TV, and even mobile devices. All these features come at a price.

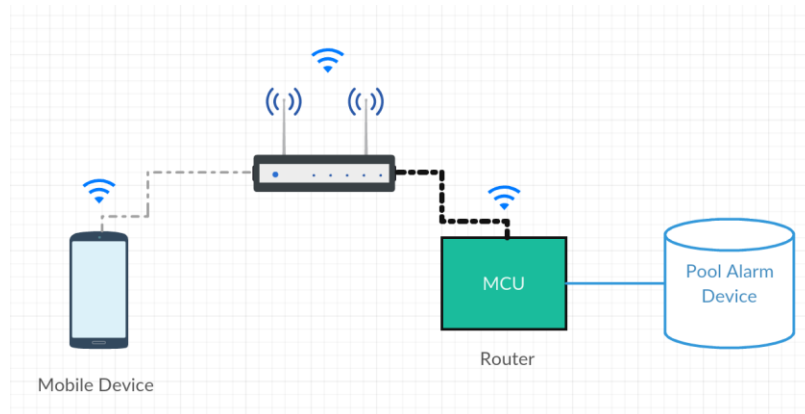

Figure 6: Wireless Communication through Wi-Fi Model

Wi-Fi is very expensive because all Wi-Fi must have a router. To have thus said router the user must hire someone to install the router. Wi-Fi also is very thirsty for power. It will

continuously use approximately 30 mW of power, whether the user is connected to a device transferring data or not. There are a few programmable boards that have Wi-Fi built into them, but it is less likely, as the manufacturing cost will be driven up from having such a feature. Based on the large range and the ability to have multiple devices connected with ease, Wi-Fi, seems to be the best method of wireless communication.

3.2.3.2.1 ESP8266

The ESP8266 is a Wi-Fi module produced by Espressif Systems. It is very diverse chip capable of integrating with many online resources. It is capable of providing full internet connectivity in a compact size. The ESP8266 is a low power chip with a 32-bit CPU capable of a 802.11b mode + 19.5dBm output power. Most Wi-Fi chips withdraw a large current consumption when activated, the great think about this chip is that it is low in comparison to others out in the market. The current consumption of 250mA when active with less than 10uA of leakage current. The ESP8266 is very well used for DIY project for not only its low power consumption, but its market value. The chip is capable of functioning under operating temperatures of -40 degrees Celsius to approximately 125 degrees Celsius. The Operating voltage is approximately 2.5 V to ~3.6V and its typical frequency is approximately 80 MHz. Depending on where you buy the ESP8266, the prices may range from \$4 to \$6. This is truly a steal for what the ESP8266 is capable of accomplishing.

3.2.3.2.2 ESP32

The ESP32 is a very diverse wireless communication chip. It capable of Wi-Fi, Bluetooth, and Bluetooth LE for various applications. With the diversity of wireless communications, it comes equipped with two CPU to be able to control and power the individual modules appropriately. The Bluetooth compatibility runs on Bluetooth 4.2 and BLE, and the Wi-Fi is a 802.11b at HT40. This chip also has an integrated 520 KB SRAM, a 32kHz crystal oscillator, and a built in Flash. The ESP32 has integrated touch sensors, temperature sensors, and Hall effect sensors. Generally, the ESP32 can operate in temperature between -40 degrees Celsius and 125 degree Celsius. The ESP32 is also a well know DIY chip with low power coprocessor and a low attractive price in the market. Depending on where you buy the ESP32, prices may vary but they typically range between \$6 to \$12. This makes the ESP32 a great buy for the the feature that are compact in the small chip.

3.2.3.2.3 ATWINC1500



The ATWINC1500 is an affordable Wi-Fi controller which is built to consume minimal amount of power. This Wi-Fi module is specifically built to operate and work well with Internet of Things (IoT) applications. The ATWINC1500 come with integrated Power Amplifier (PA), Low-Noise Amplifier (LNA), and Power Management. It has the capability to operate under temperatures ranging between -40 degrees Celcius and 85 degrees Celsius. The ATWINC1500 also operates in voltage ranging from 2.7 volts to 3.6 volts. This chip may consume up to 268mA when transmitting, and approximately 61mA when receiving. This chip is less commonly used due to its strict IoT interface. Depending on where you buy from the ATWINC1500 can go for as low as \$10 and as high as \$20. This would make the ATWINC1500 a questionable purchasing. Everything would have to

depend on what the application is being built for, as it has been addressed that this chip is in better used for Internet of Things application purposes only.

3.2.3.3 Wireless Communication Choice

Below is a table comparing the specifications for each Wi-Fi modules.

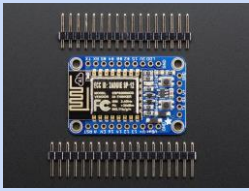
Table 1: Wi-Fi Comparison Table

Board	ESP8266	ESP32	ATWINC1500
	 <p><i>Figure 7: ESP8266 [3]</i></p>	 <p><i>Figure 8: ESP32 [4]</i></p>	 <p><i>Figure 9: ATWINC1500 [5]</i></p>
MCU	Tensilica L106	Xtensa LX6	Cortus APS3
SRAM	50 KB	520 KB	128 KB
General I/O Pins Count	17	34	28
Maximum Clock Frequency	52 MHz	60 MHz	48 MHz
Operating Voltages	2.5V - 3.6V	1.8V - 3.6V	2.7V - 3.6V
Temperature Ranges	-40°C - 125°C	40°C - 125°C	-40°C - 85°C
Maximum Power Consumption	612 mW	4320 mW	1008 mW
Price	\$3.99	\$9.95	\$18.56

After extensive research, the Baby Buoy team has decided to go with the ESP8266 as the preferred choice in wireless communication. The ESP8266 would work perfectly with the microcontroller in the Baby Buoy Project. It is diverse and capable of achieving the desired task of providing Wi-Fi connectivity with multiple devices. The ESP8266 is also fair in price, sitting in the lower end of the market at approximately \$4 depending on where you buy the chip from. It is very low power while active and consume minimal current while it is in operation. The ESP8266 is also to withstand large amounts of large and cold indexes, which would be a perfect fit for the outside environment of the Baby Buoy. The ESP32

came in at a close second option, but its large amount of power consumption would be something to budget with the rest of the components. The ATWINC1500 would be unable to be used as it operates best with Internet of Things (IoT) applications. The ATWINC1500 is also much more expensive and would hinder our max budget greatly. Therefore, the team has decided on the ESP8266 as the best option for the Baby Buoy project. Above are descriptive paragraphs going into detail on each of these Wi-Fi modules

3.3 Microcontroller

The Baby Buoy system will be using one microcontroller unit, which will act as the “brain” of the whole system. The MCU (microcontroller unit) has a major task of deciphering the data given to it by any subsystem and choosing what to do with that data. The PIR sensor will trigger the IR camera if heat is detected above the water. The MCU will process the data and decide what to do with the data. The IR camera will be sending data to the MCU and decide whether to trigger the alarm or not. The MCU should also be capable of being integrated with a WiFi module or have a built-in WiFi module. The WiFi capability allows for communication with the users' mobile device.

There are several aspects to deciding what microcontroller will be best for our system approach. We need an MCU that is capable of processing all the data, with a programming language that the team is comfortable with. The MCU should also be capable of being connected to the internet to communicate with the user when necessary. More importantly, the cost of the MCU should be within the project budget and consume low power. All MCUs provide memory, a processor core, and programmable input/outputs.

3.3.1 Microcontroller Options

There is a large variety of microcontrollers to choose from. The TI (Texas Instruments) microcontroller was the first choice for our system since it has been used in several of the classes taught at the university, of which several team members have experience with. The other options were the Arduino Uno and the Raspberry Pi. The Arduino Uno uses an Atmel microcontroller, while the Raspberry Pi uses the Broadcom microcontroller.

3.3.1.1 Atmel megaAVR Series

The Atmel megaAVR microcontroller series utilizes an 8-bit CPU with self-programmability and cost-effective in-circuit upgrades. The megaAVR MCUs are ideal for large amounts of coding, while also utilizing picoPower technology that helps minimize power consumption. The megaAVR series also has a vast amount of online resources and tutorials for user related projects. This is a huge benefit as those online resources can be hard to come across for other MCUs. The megaAVR series is fairly inexpensive which helps the team stay under project budget.

3.3.1.1.1 ATmega328P

The ATmega328P is a high-performance microchip manufactured by Atmel. The ATmega328P has 23 programmable I/O pins, where 15 pins are digital and 8 pins are

analog. The ATmega328P microchip has operating voltages of 1.8V - 5.5V, and temperature ranges of -40°C - 105°C. The operating voltages and temperature ranges are more than enough for the needs of the system. The ATmega328P operates at 1.8V, 25°C (temperature), 1MHz (speed) with an active draw of 0.2mA (current). This equates to 0.36mW of power consumption.

The ATmega328P microchip has been used for various projects. Given the vast amount of online resources and tutorials, it is expected that this microchip is safe and reliable. The price for the microchip is \$2.14 via the Digi-Key website. The most common system based on this microchip is the Arduino Uno. The Arduino R3 is a revision of the original Arduino Uno, where certain problems and features have been improved.

3.3.1.1.1.1 Arduino Uno R3

The Arduino Uno R3 is a microcontroller based on the ATmega328P microchip. The Arduino Uno R3 has 6 analog inputs, 14 digital I/O pins, and a 16 MHz quartz crystal. A neat design of the Uno R3 is that you can tinker with it without worrying too much about damaging it since the microchip can be easily replaced. The Uno R3 is an 8-bit microcontroller with flash memory of 32k bytes. The Uno R3 doesn't have built in Wi-Fi, which would increase the cost of the overall microcontroller unit. An ESP8266 Wi-Fi chip would have to be integrated in order to get Wi-Fi functionality.

Some of the special features of the Uno R3 is that it has a power-on reset and programmable brown-out detection. Brown-out detection allows for protection of the microcontroller in case something goes wrong. Another neat feature is that it has 6 sleep modes: Idle, ADC noise reduction, power-save, power-down, standby, and extended standby. The Arduino Uno R3 is a very popular amongst new users who are learning how to create electronic hardware and software. Unfortunately, the processing power of the Arduino R3 is not enough for all the image processing and computer vision that we have to do. The Uno R3 microcontroller board costs \$22 via the Arduino website.

3.3.1.1.1.1.1 ESP8266 Wireless Chip

The ESP8266 was originally constructed to operate for use in the Internet of Things (IoT), wearable technology, and mobile devices. It is very small in stature, so it will not take up too much real estate in a PCB board and takes in extremely low-power consumptions. It also holds a feature that places the Wi-Fi capability into a "standby" mode until Wi-Fi is needed which, again, is very helpful when it comes to power consumption. The ESP8266 houses a 32-bit microcontroller unit, which can sync with other applications and sensors, as well as, host those said applications. With its convenience in power intake and size of the actual chip, this chip is utilized in many major applications such as home appliances, baby monitors, IP cameras, etc. The ESP8266 chip costs \$1.60 via grid connect website.

3.3.1.1.2 ATmega644PA

The ATmega644PA is the next upgrade from the ATmega328P microchip. The ATmega644PA provides 32 general purpose I/O pins, 64 KB of Flash memory, and 4 KB of RAM. It runs under the same operating voltages and temperatures of the ATmega328P; 1.8V - 5.5V and -40°C - 105°C. Given that the ATmega644PA is of the

same family as the ATmega328P with very minor exceptions, it can be fairly easy to adapt the code from the ATmega328P onto the ATmega644PA. The same online resources can be used, with the exception that the pins of the ATmega644PA have to be used. The ATmega328P has already been proven to be a valuable and reliable microchip, so it is unlikely that the ATmega644PA will be otherwise. The ATmega644PA has all the major functionalities as the ATmega328P, except it draws more power given that it provides more memory and pins.

3.3.1.2 TI MSP43x4xx Series

The TI MSP43x4xx is a series of microcontrollers manufactured by TI (Texas Instruments). These microcontrollers are the standard across UCF for Electrical and Computer Engineering students. Due to the teams prior experience with this family of boards, it was the first option that came to our minds. It incorporates a 16-bit RISC CPU, peripherals and a flexible clock system. The clock system interconnects a von Neumann common MAB (memory address bus) and a MDB (memory data bus). The TI MSP43x4xx also offers an ultra-low power consumption architecture with high-performance analog for precision management.

3.3.1.2.1 TI MSP430FG4618/F2013 Experimenter Board

The TI MSP430FG4618 is a microcontroller board used in the Embedded Systems class offered at UCF. This board offers ultra-low power consumption with an active mode of 2.2V, 1 MHz (speed) and active draw of 400 μ A (current). It also offers low supply-voltages in the range of 1.8V-3.6V. The board also offers 116 KB of Flash, 8 KB of ROM, 80 general I/O pins, and two 16-bit timers. The board also contains an MSP430F2013 microchip that contains a built in 16-bit timer and 10 I/O pins.

Given the familiarity with this board, we thought that it was the best choice to choose from. After further research, we realized that this board wouldn't be sufficient for all the image processing and computer vision that we have to do with both cameras of the Baby Buoy. Some of the features such as the LCD screen are nice, but ineffective for our needs. The price of the TI MSP430FG4618 experimenter board is way too expensive as well, reaching up to \$117 per unit from the TI website.

3.3.1.3 Broadcom BCM283x Series

The Broadcom BCM283x is an SoC (System on Chip) used in the the first Raspberry Pi board. The BCM283x offers 32-bit RISC CPU, 700 MHz clock rate (with an acceptable over clock of 800 MHz) and an ARMv6 architecture. The BCM283x also offers a Videocore 4 GPU, offering 24 GFLOPS of performance with 1080p blu-ray quality videos. A variety of programming languages is offered, but we will primary be using C/C++ or Python. The BCM283x series offers the capability to interpolate and filter sensor outputs which is critical for image processing.

3.3.1.3.1 Raspberry Pi 3 B

The Raspberry Pi 3 B is a microcontroller originally based on its predecessor, the Raspberry Pi 2 B. The Raspberry Pi 3 B, which is manufactured by Raspberry Pi costs

\$29.99 from the MicroCenter website. This board offers a Cortex-A53 high efficiency processor that implements the ARMv8-A architecture and a quad core 1.2GHz Broadcom BCM2837 64-bit microchip. The Cortex-A53 processors offers 4 cores, each with an L1 memory system and a single shared L2 cache. The Raspberry Pi 3 B also offers an integrated BCM43438 chip, which offers wireless LAN and BLE (Bluetooth Low Energy). The Raspberry Pi 3 B also offers an integrated GPU, with 1080p video encode/decode.

The integrated BCM43438 chip is a nice feature, since it is the main component for interacting with the user. Having the integrated chip also brings the cost down when compared to the other microcontroller boards where a separate chip is necessary for wireless internet connection. The chip offers 10/100 Mbit/s of direct Ethernet (via the Ethernet port), 802.11 n wireless LAN and Bluetooth 4.1. The board contains 40 extended general I/O pins, 4 USB 2 ports, and a CSI camera port for connecting Raspberry Pi cameras. The idle power usage of the Raspberry Pi 3 B is 1.5W, using 5V and 300mA (current).

3.3.1.3.1.1 BCM43438 Integrated Chip

The BCM43438 is a chip that is directly integrated into the Raspberry Pi 3 B. The chip provides 2.4 GHz 802.11n wireless LAN, Bluetooth 4.1 and Bluetooth Low Energy. The chip provides a convenient way of being able to connect to the internet, without having to go through the hassle of integrating a wireless chip onto the microcontroller. The chip provides connection to the 2.4 GHz frequency for wireless signals. This is extremely convenient since the 2.4 GHz frequency band can be found in most homes. Bluetooth 4.1 provides improved data transfers between devices and improved coexistence with 4G (LTE) signals. Bluetooth 4.1 also provides smart connectivity, which basically allows the developer to control the signal timeout for reconnection. Battery life is greatly increased, and connections drop outs are reduced.

3.3.1.3.1.2 VideoCore 4 GPU

The VideoCore 4 GPU (Graphics Processing Unit) is the integrated GPU card for the Raspberry Pi 3 B. It is a low power, high performance GPU that provides 24 GFLOPS. FLOPS (Floating Point Operations per Second) is a measure of computer performance. It is fairly reliable in showing how well hardware or software works. The VideoCore 4 also offers 1080p video encode and decode. It can hardware decode various different formats of video at 1080p such as: H264, MPEG1, MPEG2, MPEG4, VC1, AVS, and MJPG. The Raspberry Pi 3 B offers an HDMI port for direct video feed. Although the Raspberry Pi 3 B offers an integrated GPU, our system won't need any form of direct video feed. The video streaming will be done via wireless internet to the users phone. It should be known that the VideoCore 4 GPU can be compared to that of the original Xbox.

3.3.2 Microcontroller Board Comparisons

This section covers the comparisons between the top 4 microcontroller boards of choice. The comparisons are based on the cost, power consumption, memory size, clock frequency and operating temperatures of each board. The board will require a robust clock frequency

and memory size to analyze high quality video input data, however, power consumption must be minimized to preserve battery life.

3.3.2.1 Cost

The cost of each microcontroller board is extremely important in deciding which board to use for the Baby Buoy project. We have to maintain budget throughout the project, such that it can still be affordable at the end of the project. The end goal is for the project to be superior and more affordable than the cFloat and SafeFamilyLife pool alarms.

Table 2 shows the unit price of each microchip and microcontroller board. The MSP430FG4618/F2013 is about 4 times more expensive than the Raspberry Pi 3 B and 5 times more expensive than the Arduino Uno R3. There is no justification for choosing the MSP430 board considering its price point. The Arduino Uno R3, the ATmega644PA, and the Raspberry Pi 3 B have much more affordable prices. Even though the microchip for the MSP430 isn't as expensive as the microcontroller board price, it is still significantly more expensive than its counterparts prices for its respective microchip. Overall, the more expensive the microcontroller is, the more expensive the end product will be.

3.3.2.2 Power Consumption

The power consumption of our Baby Buoy device is not to be expended. The Baby Buoy is always to be attentive to its surroundings once it is powered on. The MCU that will be governing our device must be low power consumption while still providing enough power for its subsystems. Having two cameras feeding off of the power along with the Wi-Fi chip sending and receiving signal throughout us, will have to be placed into consideration for when deciding on a particular microcontroller board.

Table 2 shows the different microchip/microcontroller boards and the amount of power each consume individually. Based on the four that are in comparison the Arduino Uno R3 will be consuming the least amount of power, based on the voltage and current input. The board with the most amount of power consumption is the Raspberry Pi 3 B at 3500 mW, based on the amount of voltage and current input. The MSP430FG4618/F2013 is considerably good with power consumption, but not as great as the Arduino Uno R3 or the ATmega644PA microchip.

3.3.2.3 Memory Size

The memory in a microcontroller board varies depending on the product and what they are meant for. The Arduino Uno R3 and the ATmega644PA microchip are more user friendly and beginner microcontrollers. The Raspberry Pi 3 B is a more advanced microcontroller board option where users have more memory and RAM to create more advanced projects. The MSP430FG4618/F2013 is a microcontroller board designed for low power consumption embedded applications.

Random Access Memory (RAM) is the data space that is used for temporarily holding values during normal program execution. RAM is organized into several "registers" where each "register" has its own unique address. Registers are locations in memory where you can read data or write data. The more RAM a microcontroller has, the more temporary

information it can hold. Memory in microcontrollers can vary, the most prominent for each board in our comparison is the L2 cache and Flash memory. Cache memory essentially stores program instructions and data that are repeatedly used through program operation. This can also be data that the CPU will likely need next. L1 cache is extremely fast, but small. L2 cache can be embedded onto the CPU and can be accessed quicker than “main” memory. Flash memory is non-volatile memory that can be electrically erased and reprogrammed. Stored data is kept even after powering the microcontroller board on or off.

Table 2 shows the RAM for all four microchips/microcontroller boards, the L2 cache for the Raspberry Pi 3 B, the flash memory for the Arduino Uno R3, the ATmega644PA microchip, and MSP430FG4618/F2013. The Raspberry Pi 3 B has the most RAM, compared to the other microcontroller boards and microchips. This allows for more temporary holding of information. The Raspberry Pi 3 B doesn't have any flash memory, instead it has L2 cache. This is expected since it's a very powerful microcontroller board. The Arduino Uno R3, ATmega644PA microchip, and the MSP430 have flash memory readily available, with the MSP430 having almost 4 times more flash memory than the Arduino Uno R3. It is still apparent that the Raspberry Pi 3 B is the strongest competitor in terms of memory, but that memory is unnecessary for the needs of Baby Buoy system. The ATmega644PA has a much more adequate memory size for the code and algorithms that will be created for the system.

3.3.2.4 Clock Frequency

The clock frequency is the rate of instruction execution for a microcontroller board. The higher the clock frequency, the faster the CPU can handle and perform tasks. It is important that the Baby Buoy system have a large clock frequency in order to perform all the image processing and computer vision algorithms that are necessary to detect motion and heat. Without a large clock frequency, we wouldn't be able to perform all the tasks that the CPU will have to handle due to these algorithms. The NoIR camera will perform as the live video feed for when an object is detected by the IR emitter and receiver. We need to ensure that the CPU can handle all the tasks of all the subsystems. The clock frequency is one of the most important factors in deciding which microcontroller board to choose.

Table 2 shows the clock frequency for each microchip/microcontroller board. It is apparent that the Raspberry Pi 3 B has the highest clock frequency. The MSP430 has the lowest clock frequency, while the Arduino Uno R3 and the ATmega644PA have the same clock frequency. The Arduino Uno R3 and the ATmega644PA microchip have a clock frequency of 20 MHz while the Raspberry Pi 3 B has a 1.2 GHz clock frequency. This is 60 times faster than its counterparts, which is a superior increase in terms of computing power. The Raspberry Pi 3 B has an exceptional clock frequency, but for the task of the project, it will not be used. The Arduino Uno R3 and the ATmega644PA microchip have a clock frequency that is much more reasonable for what the Baby Buoy system is meant to do.

3.3.2.5 Operating Temperatures

The operating temperature on a microcontroller depicts that a device will be operating efficiently within the given range of temperature. This range is varied based on the devices

function and application use. There is typically a minimum operating temperature that is the coldest a microcontroller can be and still operate. There is a maximum operating temperature which is the hottest it be at a given moment in time without malfunctioning, or force shutdown.

For the Baby Buoy project, a board that is capable of taking on a large heat tolerance is very much in need. Being that the device will be mounted on the side of a pool, outside, it will endure large amounts of continuous heat throughout the day. At night, it must be able to take on colder temperatures since temperature drops from daytime to nighttime.

Table 2 goes over the temperature ranges that each each microcontroller board and microchip can operate in. Based on the research, the Arduino Uno R3 and the ATmega644PA microchip have the largest operating temperature ranges. The low temperature value is how cold it can operate, and the high temperature value is how hot the board can operate before it malfunctions. Both the Raspberry Pi 3 B and the MSP430FG4618/F2013 have the operating temperature ranges. However, the Arduino Uno R3 and the ATmega644PA microchip have a larger operating temperature range which makes them more versatile to extreme conditions as opposed to the other two microcontroller boards.

3.3.3 Microcontroller Choice

After comparing the features of all the microcontrollers, the ATmega644PA is the optimum choice for the Baby Buoy project. Of the four microcontrollers, the ATmega644P offers the best processing power needed for the project, at the most cost efficient price. The ATmega644P microchip costs \$3.59, which is considerably cheaper than the MSP430 board that costs \$117, where the microchip prices are \$13.59 and \$2.33 for the MSP430FG4618 and F2013 microchips respectively.

The ATmega644PA has a very low power consumption that is extremely important in being able to run the Baby Buoy system continuously for more than 1 day. The 5000mAh Li-Po battery is more than sufficient for the needs of the microchip and the Baby Buoy system. The operating temperatures for all the microcontrollers are more than enough for the environment that the system will be placed in. It isn't the biggest factor in deciding which microcontroller to use, considering that the typical weather in Florida is 28°C. The number of pins (32) that the ATmega644P microchip offers is more of a convenience than a necessity, since there isn't that many subsystems that will be connected to it.

The ATmega644P microchip has various online tutorials and documents for learning how to use the board and how to create projects with it. This is relevant since the ATmega644P microchip is based on the same family as the popular Arduino Uno R3 microcontroller board that utilizes the ATmega328P microchip. Although there are minor differences between the ATmega644P microchip and the Arduino Uno R3 microcontroller board, portability is not too difficult. It should be known that the Raspberry Pi 3 B is the only microcontroller with a GPU from the four microcontroller choices. Below is a table comparing the specifications for each microcontroller board and microchip.

Table 2: Microcontroller Boards and Microchips Specifications Comparison

Board	Raspberry Pi 3 B	Arduino Uno R3	Arduino Uno ATmega644	MSP430FG4618/F2013
Microchip	Broadcom BCM2837	ATmega 328P	ATmega644PA	MSP430FG4618 MSP430F2013
Operating Voltages	4.75V - 5.25V	1.8V - 5.5V	1.8V - 5.5V	1.8V - 3.6V
Temperature Ranges	-40°C - 85°C	-40°C - 105°C	-40°C - 105°C	-40°C - 85°C
Maximum Clock Frequency	1.2 GHz	20 MHz	20 MHz	8 MHz
Memory	512 KB L2 Cache	32 KB Flash	64 KB Flash	116 KB Flash
RAM	1 GB	2 KB	4 KB	8 KB
GPU	Videocore 4 GPU	None	None	None
General I/O Pins Count	40	23	32	80
USB Ports	4	1	1	0
8-bit Timers	0	2	2	0
16-bit Timers	0	1	1	2
32-bit Timers	1	0	0	0
Active Power Consumption	3500 mW	0.36 mW	0.72 mW	0.88 mW
Built-In Wi-Fi	Yes	No	No	Yes
Price	\$29.99	\$22.00	\$3.59 (microchip only)	\$117.00

3.4 Battery

Since the Baby Buoy will be solar powered, it requires a battery back-up to power it at night and in cloudy days. Batteries are devices capable of storing electrical energy via chemical reactions within their cells. Batteries consist of three main components: the cathode, the anode, and the electrolyte. During discharge, the anode is the negative electrode while the cathode has a positive charge. An oxidation reaction occurs in the anode that releases electrons into the external circuit which are accepted by the cathode, the accumulation of electrons in the anode results in the electric potential of the battery. The electrolyte is a chemical medium that separates the electrodes and transports ions between the anode and cathode. During recharge, an external voltage source causes the flow of electrons to change direction and the anode and cathode polarities are reversed. In the Baby Buoy, the external voltage sources are the solar cells. It is important to note that the flow of current is opposite to the flow of electrons, therefore current flows into the anode and out of the cathode during discharge.

3.4.1 Battery Types and Applications

Batteries are separated into two major types, primary and secondary batteries. Primary batteries cannot be recharged, their chemical reactions are irreversible. They are used when recharging is difficult or impossible, for example, in pacemakers or animal trackers. Alkaline batteries are a common type of primary battery, they are safe and can be stored for prolonged periods of time. However, these batteries have low load current, therefore they can only be used in low current applications.

Secondary batteries are also known as rechargeable batteries, their electrochemical reactions can be reversed by applying an external voltage in the opposite direction of the battery operation. These batteries have a higher current output and are used when it would be impractical and costly to swap out primary batteries regularly. Secondary batteries are used in mobile devices, RC planes, and other high load applications. These batteries are classified into subtypes according to their chemical composition, some of these types include Lithium-Ion, Nickel Cadmium, Lead-Acid, and Nickel-Metal Hydride.

3.4.1.1 Lead-Acid

Lead-Acid Batteries are larger and heavier than other secondary batteries, for this reason, they are not used in portable devices. Lead-Acid are the oldest of the rechargeable batteries and are very reliable and low-cost. These batteries are commonly used in vehicles ignitions due to their ability to generate high current surges. Lead-Acid batteries are low maintenance and have low self-discharge rates. Limitations include environmental hazard due to lead content and low energy density. The life of these batteries ranges between 200-300 recharge cycles, relatively low compared to other rechargeable batteries. They are a good choice for applications that require only occasional deep discharges.

3.4.1.2 Nickel Cadmium (Ni-Cd)

Nickel Cadmium batteries consist of metallic cadmium electrodes and a nickel oxide hydroxide electrolyte. These batteries are also known as NiCad batteries, they have long

life cycles and their ability to hold a charge when not in use is excellent. NiCad batteries' best attribute is their ability to deliver their full rated capacity at high discharge rates. They come in a variety of sizes, including AAA to D standard sizes, making them a viable option for portable devices. Some disadvantages of NiCad include its relatively low energy density compared to other rechargeable batteries. Its high self-discharge rate and environmental impact due to toxic metals in their construction. Also, the future capacity is lowered if a partially charged battery is recharged, this is known as the "memory effect". NiCad batteries have an average life of 2000 recharge cycles and an efficiency of 70-90%.

3.4.1.3 Nickel-Metal Hydride (Ni-MH)

Nickel-Metal Hydride are like NiCad batteries, they use the same positive electrode and electrolyte, however the negative electrode is a hydrogen-absorbing alloy. These batteries have higher capacity and energy density, double or triple a similarly sized NiCad. They are also not afflicted by the "memory effect", making them superior to NiCad batteries in that respect. They are more environmentally friendly with only mildly toxic components. Some limitations include low discharge current, high self-discharge rate, and high maintenance to prevent crystalline formation. Ni-MH batteries have wide ranging average life between 180-2000 recharge cycles and efficiencies of 66-92%. They require more complex charging procedures since they generate more heat and longer charging periods than NiCad batteries.

3.4.1.4 Lithium-Ion (Li-Ion)

The most common rechargeable battery used in mobile devices, the lithium-ion battery excels with its high energy density, low self-discharge, lightweight construction and immunity to the memory effect. Li-Ion battery life spans 400-1200 recharge cycles depending on the specific chemistry of the battery and efficiencies of 80-90%. The main disadvantage of Li-Ion batteries is that they cannot be recharged by a regular power supply, a specialized charging procedure must be followed to ensure the battery does not overheat and gets damaged. There are two main phases, a constant current phase and a constant voltage phase. First, the charger applies a constant current, normally between 0.5C and 0.7C, where C is the capacity of the battery being charged, usually given in mAh (milliamp-hour) or Ah (amp-hour). This is done until the battery voltage reaches 4.2V, then the charger turns to the constant voltage phase, maintaining the voltage at 4.2V until the current drops to 0.1C-0.03C, at this point the battery is considered fully charged.

3.4.1.5 Lithium-Ion Polymer (Li-Po)

Lithium-Ion Polymer batteries are a type of Li-Ion battery that has a polymer electrolyte instead of liquid. They have the same advantages and charging procedure as the Li-Ion batteries. The main benefit of Li-Po over Li-Ion batteries is their design flexibility, they can be made thinner and in any shape the manufacturer desires. The price of these batteries is also slightly higher than comparable Li-Ion batteries. They are safer than Li-Ion batteries but have slightly lower energy density. Li-Po batteries can have high discharge rates, which reduces their life to about 300 recharge cycles.

3.4.2 Battery Choice

Below is a table comparing the specifications of each battery, the Li-Po battery was chosen due to its compactness, which surpasses that of similar Li-Ion batteries.

Table 3: Battery Comparison

Battery	Lead-Acid	Nickel Cadmium (Ni-Cd)	Nickel-Metal Hydride (Ni-MH)	Lithium-Ion(Li-Ion)	Lithium Polymer (Li-Po)
No memory effect	✓		✓	✓	✓
Compact		✓	✓	✓	✓
Low self-discharge	✓			✓	✓
Not Toxic			✓	✓	✓
High discharge rate	✓	✓		✓	✓

3.5 Alarm System

The alarm system is a key feature that will be implemented on the Baby Buoy project. Being that Baby Buoy is an advanced pool alarm, the sound that it will emitted may have the difference between life and death. As described in “Similar Projects”, Baby Buoy will have an alarm mounted on the actual device that will be installed on the side of the pool, and there will be a house unit where the user may place anywhere throughout the inside of their home.

3.5.1 Piezo Buzzer

The Piezo Buzzer is the perfect element to creating a loud pitch sound to alert anyone of danger around the pool or inside the house. Piezo Buzzers come in many different sizes and models and are very commonly used in alarms. The great thing about this buzzer is how small it is. Throughout the different models, the size of the horn stays fairly small which is perfect for the compact style of the Baby Buoy. The Piezo Buzzer will be great for outdoor use having the operation temperature range between -30°C to approximately 85°C. This temperature range is the same through all Piezo Buzzer models. The large temperature range that all Piezo Buzzer have will be perfect for the indoor units as well. The pitch of sound the Buzzer is capable of outputting very well depends on the model. For the Baby Buoy project, the team is going to be installing a buzzer that is anywhere in between 60-90 dB. The number of decibels may be manipulated by the amount of voltage

that is given to the buzzer. The higher the voltage the louder the sound it emits, the lower the voltage the softer the sound.

The Piezo Buzzer is very easy to install only needing two wires and a power supply. The power supply may be found on a programmable board or a battery. In the case of the Baby Buoy the alarm will be attached on the programmable board, which will be powered by the battery. The Piezo Buzzer will be set to sound off if it passes certain test case within the program. If all test cases output to be “true” the Buzzer will sound alerting anyone in the perimeter of danger. This is the logic that will be exercised in the code. This test cases will lessen the number of false alarms, or even eliminate any possibility of false alarms.

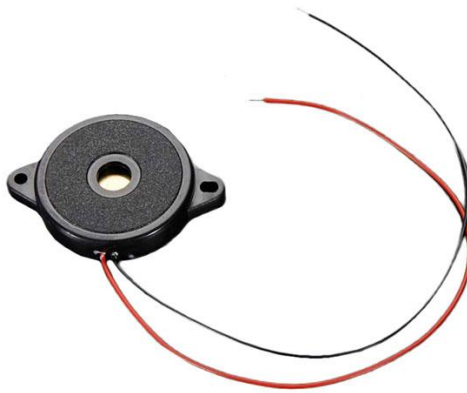

Figure 10: Piezo Buzzer [6]

3.6 Image Processing

Image processing is a form of signal processing where the general input would be an image and the output might be an image, feature, particular color, characteristic, that is associated with the input image. This type of technology is rapidly growing in most recent years. Image Processing may be found in airport security as well and home security. Most security camera systems come with image processing integrated in the software. There are two main forms of image processing, analogue and digital image processing. Digital image processing techniques are very useful in manipulating digital images through the use of a computer. Being using digital techniques, there are three phases that data must go through. Those being pre-processing, enhancement, and display. All three phases must be completed properly so that information is extracted properly from an image.

So that an image may be digitally processed, a image function $f(x,y)$ is constructed so that the amplitude and the spatiality of the image is being put into consideration. This is done by converting data into digital form which can be done either through sampling or quantization. The spatial resolution of the digital image is determined by the sampling rate and quantization determines that amount of grey levels are found within an image. The

levels of quantization must be very high so that the human eye can depict details of shading within an image. The collection of data is all towards enhancing the image so it can be recognizable and interpreted by humans. Based on the human biology, our vision is much more sensitive when it comes to dark colors that contrast in comparison to lighter colors that illuminate. Therefore, taking into consideration the quantization, which makes a collection of the grey scale within an image in very important in depicting the overall image.

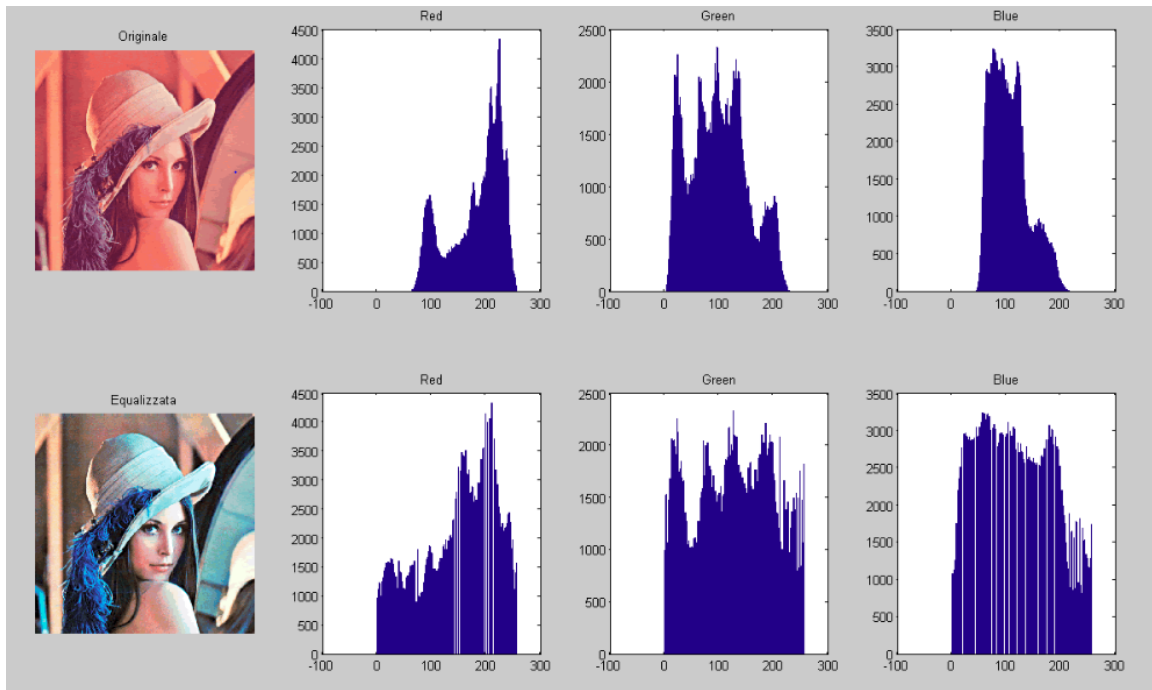

Figure 11: Image Processing Data Exhibition [7]

Figure 11 illustrates an image of a woman to the left and how the image is processed and broken down into the primary components red, green and blue (RGB). On the top left corner is the original image that was captured. One can see that it is very pink or red after development. Therefore you can visually see the spike of red in the graph to the immediate right of the original image. There is also a fairly large spike in blue that can be visually seen from here outstanding hair. In the green graph there can almost be a linear line that can be draw from the base of green that there are in the image. The image below is seen to edited to make the original look more realistic. From the edit, you can see from in the RGB graphs that this image is more balanced throughout the scope which makes it more pleasing and realistic as a result.

In the Baby Buoy Project, image processing will be programmed into the software to grab images that are being inputted by both cameras that will be installed into the the device. This crucial feature will be tied together with object recognition so that the computer may determine any figure(s) that may be pulled in from the image. The camera that is at the level of the water will be able to determine if the image has a small object, such as a child, roaming in the perimeter of the pool. Which when then send an alert to the users phone. The

second camera will pull in images from under the surface. This camera will determine if a moving object has fallen inside the pool. At this stage, all alarms will be activated to alert anyone nearby of danger. Throughout this logic, image processing role in pulling in images and turning that image into data so that the computer may depict what it is seeing.

3.7 Computer Vision

Computer vision is an emerging technology that is embedded in different devices that we use in our day to day life. For example, we can find it in any of our mobile phones, tablets, of photo cameras. It is seen in video games that we play, in access control systems, and it even supports certain medical diagnosis and surgery assistance. Computer vision deals with the problem of understanding automatically image of video content. This is an ability we humans perform in almost an almost unconscious manner, but it is a big deal for computers. Object recognition or the automatic identification of objects such as pedestrians, cars, movement analysis or the automatic identification of actions, are the automated extraction of 3D information from videos or images. A lot of new software and hardware engines will come out to get integrated in new smart devices such as smart glasses and smart cars.

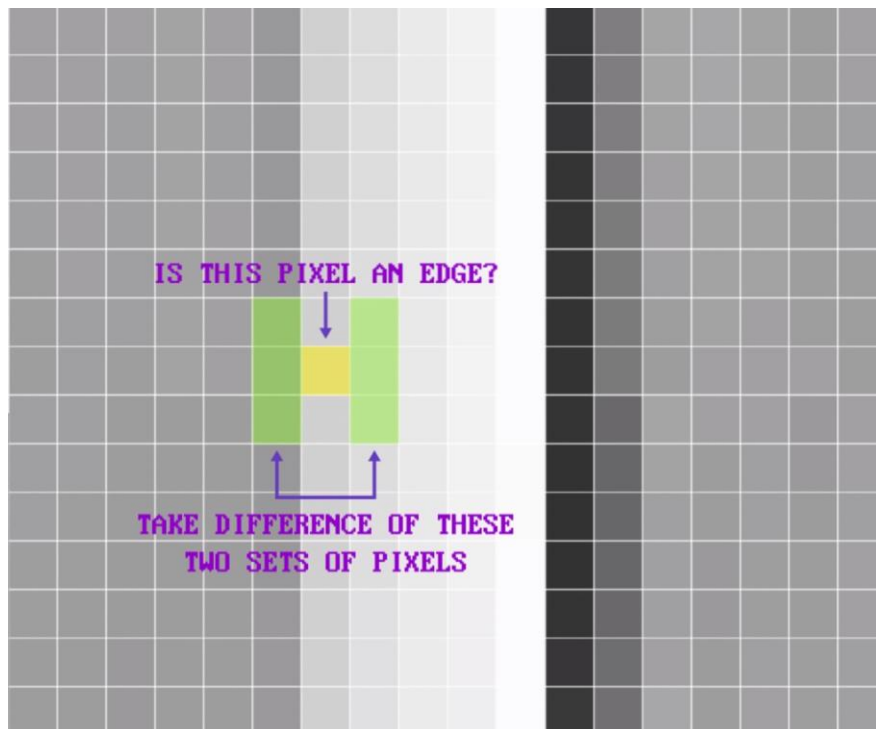

Figure 12: Computer Vision-Edge Detection

Vision is the highest bandwidth sense, and it provides a load of information about the state of the world and how to act on it. For this reason, computer scientist have been trying to give computers vision for half a century. Its goal is to give computers the ability to extract high levels of understanding from digital images and videos. Images on computers are stored as big grids of pixels. Each pixel is defined by a color that is stored in an RGB combination to define infinite color combinations. Through the use of computer vision, a

broad may be programmed to detect a certain RGB combination within a video or image content. An algorithm like this might start in the upper right of an image and scan each pixel one at a time calculating the difference from the target color combination. Once the scan is complete the computer will output the best match of the RGB combination which is most likely what you were targeting to begin with. This algorithm is not limited to just images, it may also be implemented to every frame in a video which will track any object that you set it to, in return.

The following example is best implemented under ideal conditions. That would include opposing colors and good lighting. This example is also only good when it comes to anything that is the size of a pixel, which is very unlikely. Features with anything larger than a single pixel, such as the edges of an object, computer vision algorithms consider small regions of pixels called patches. A patch can be defined by creating a rule that says the likely hood of a pixel being on a vertical or horizontal edge is the magnitude of the difference in color between some pixels to its left and some pixels to its right. The bigger the color difference between these two sets of pixels the more likely the pixel is on an edge. If the color difference is small it is probably not an edge at all.

Computer vision will be programmed and fine-tuned in the Baby Buoy project. It will be the eyes that will determine if there is a child inside the pool or near the pool at any moment that there is no adult vision. Computer vision will be programmed in both cameras and will be tested for multiple sized children. With the use of image processing, the computer will be able to gather the needed data to perform object recognition, divide the pixels within an image or frame of a video and determine if there are children in the perimeter to either send an alert via mobile device or set off the alarms.

3.7.1 Object detection

Object tracking and target detection are one most heavily researched field in computer vision and image processing. This has to do with a variety of applications object tracking can be used for as well as the plethora of ways it can be enacted. Not only are their different algorithms that be used to track objects but there are multiple platforms that the algorithms can be applied to, such as straight image processing with a camera, lidar scanning and depth maps images. The processes can be applied if there is some array of data for each consecutive unit of time. Some of the processes include image differencing, non-parametric local transformation, morphological based object detection, the Kanade Lucas technique, and mean shift algorithm. Since there are many algorithms that can be used we need to find what that has detection at an acceptable frame rate, has minimal processing costs, and for our purpose it be a simplistic algorithm because we only need to determine that a large enough object to be a person has entered the pool area which for the most part should be a fairly static background.

Image differencing is a simple process that finds the difference in intensities of pixels between frames. This can be done by simply subtracting the two frames and generating a different image and what remains will be new objects. In a similar fashion with an appropriate set up period, a background image is a stored as the subtraction element and is then compared with the next images in the sequence and whatever survives the subtraction

is the object. While this process is simple and probably robust enough for our needs it requires a large set of instructions and requires a large amount of storage and may take too much time to be useful.

Non-parametric local transformation is like differencing but is slightly more sophisticated. This method does not rely on actual intensity values but makes references from one pixel to pixels around it. Here a difference image is formed but instead of keeping intensity value at each pixel the pixels around the selected pixel are turned into a 1 bit for values that are greater than the reference and 0 bit for those less than reference. This creates a bit string for all the pixels of an image. These strings can be compared very quickly making it faster than absolute differencing and by being self-referencing it is not prone to error due to intensity fluctuations. This method may be enough for our needs but is still fairly processing costly with initial differencing and processing pixels individually.

Morphological based detection is a process that helps bring down process cost by analyzing by regions. This process starts by establishing and removing the background then consecutive images are deferred and then the remaining object is characterized, and then consecutive images produce objects and compare their characteristics to track their movements. This method might be doing more than we need from it since it could be effective for multiple target tracking and detailed motion tracking, but we should keep some of the methods in mind when structuring the method, we do choose.

The Kanade Lucas technique is a more complex technique. It involves starting with two consecutive images and assumes the second is the first. Then image gradients and derivatives are calculated to determine the amount to shift the second image to assume it's the first. Then first is analyzed for a distinct feature for tracking and then the direction of movement is calculated. And then this process is repeated iteratively, and the features are tracked, and the direction is stored. This is method is another efficient method that can take care of some issues of the previous processes but is said to lose some accuracy with drastic changes in direction.

The mean shift algorithm is a much more complex algorithm that compares the gradients of the images found by estimate the probability density of the gradient. This gradient is stored as a histogram and then the similarities are compared. From the start is finds its target and estimate possible movements and compares these assumptions to approximate the new location and then shifts a limited frame of the new location and shifts along the new gradient until it finds its maximum. This method might be in the region of what we are looking for but is quite complex.

There are functional options to choose from so we should probably start simple and see that we can implement something easy first to see if that's all we may need but if we end up with more time we could try the more complex method.

3.8 Solar Cell

Solar Cells, otherwise known as photovoltaic cells, are capable of converting light directly into electricity due to a material property is known as the photoelectric effect. Materials

that exhibit this property will absorb photons and release electrons, which can be captured to produce an electric current. Photovoltaic cells are made of semiconductor materials such as silicon. There are two layers of the semiconductor material stacked on each other, one is positively doped (p-type) and the other is negatively doped (n-type). Positive doping is commonly achieved by implanting Boron into the semiconductor while negative doping is done by implanting Phosphorous. The junction between the positive and negative semiconductors is known as the PN junction. An electric field will be created at the junction due to electrons from the negative side getting absorbed by acceptors in the positive side, creating a net positive charge in the n-type semiconductor and a net negative charge in the p-type. This electric field limits the flow of electrons released by the photoelectric effect to one direction. Electrodes are placed at the surface of each semiconductor to serve as current conduits, Figure 13 depicts how the solar cell works.

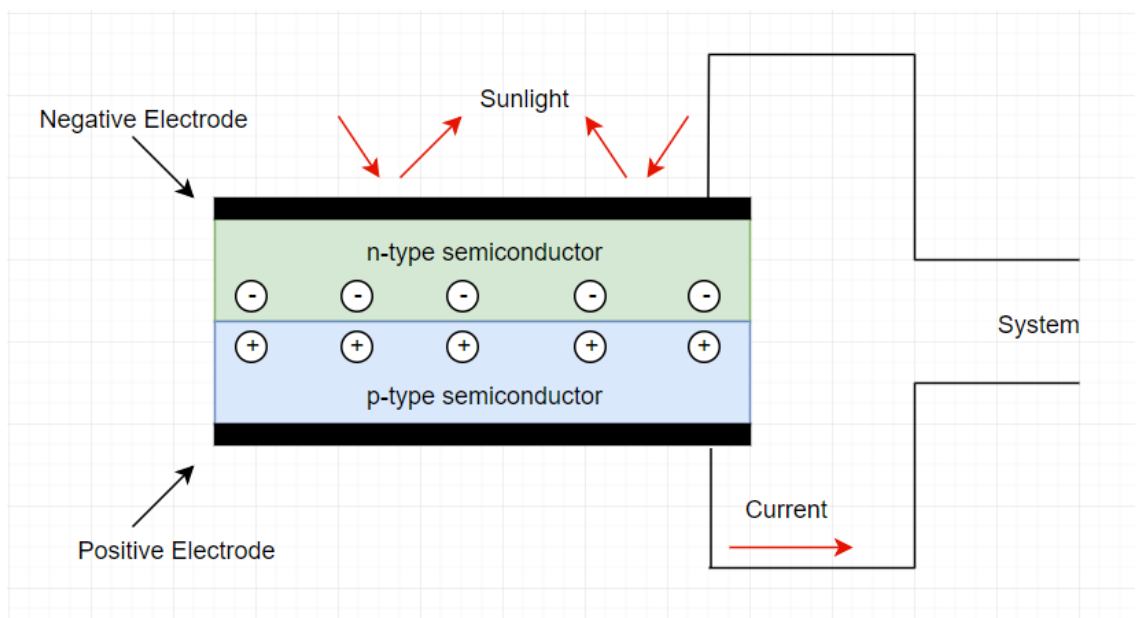

Figure 13: Photovoltaic cell technology.

Solar cells come in a variety of shapes and sizes, selecting the right panel depends on the project at hand. Photovoltaic cells are not very efficient at converting solar energy into electricity, current commercial panels have efficiencies between 15-18%. Solar cell voltage is a function of light intensity; therefore a cell will only reach its rated voltage when a light threshold is met. This limits the operation of solar powered devices to peak sun-hours, unless battery back-ups are used. Most solar panels used for power grid applications store their energy in Lead-acid batteries that are then converted to AC to power homes.

3.9. Voltage Regulation

Most microcontrollers have operating voltages ranging from 3.3-5V. However, some peripheral digital inputs will only work at 5V. On the other hand, most lithium-ion batteries used in portable devices have rated voltages of 3.7V, not to mention the fluctuation in input voltage from a photovoltaic cell throughout the day. The use of voltage regulators comes

from the need to normalize the input voltage of the system to a constant value that will be able to power all peripherals. There are two main types of voltage regulators, linear and switching. These can be either DC or AC depending on the specifications.

Linear regulators are also known as step-down regulators, they can only create a constant DC output voltage that is lower than the input. Their operation is based on voltage division where one of the resistors is variable to maintain a constant output over a range of input voltages. A transistor is used as the variable resistor by operating it in the linear region, depending on the base (BJT) or gate (MOSFET) voltage, the resistance value changes. An operational amplifier is used as a negative feedback controller to regulate the voltage to the transistor base. Linear regulators need the input voltage to be higher than the output by a certain amount in order for regulation to occur, this voltage difference is known as the dropout voltage. There are three basic types of linear regulators: Standard, low dropout (LDO), and quasi LDO regulators. The main difference between these types is the dropout voltage.

Linear regulators are simple but not very efficient. Since the input current is almost equal to the load current, the change in voltage across the regulator times the current is power dissipated as heat. The basic linear regulator design is shown in Figure 14. Other advantages of these regulators include fast response to changes in load voltage and no switching noise. Bypass capacitors are sometimes used parallel to the input voltage and load to maintain low AC impedance paths to ground. A very common linear voltage regulator used to teach about these devices is the LM7805, which drops voltages down to a constant 5 V output. The precision of these voltage regulators depend on the resistors creating the voltage divider, picking high precision resistors is necessary if the voltage needs to be within a certain tolerance. Linear regulators are also cheaper due to their simplicity.

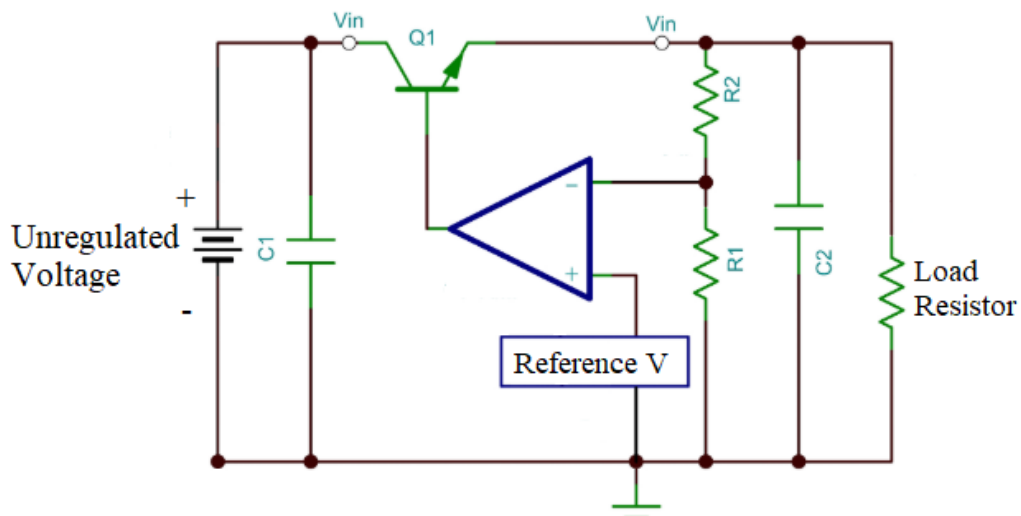

Figure 14: Basic linear voltage regulator with bypass capacitors.

Switching regulators operate by carefully opening and closing transistor switches using pulse width modulation (PWM). The circuits have inductors and capacitors that are charged

and discharged to regulate the voltage. These regulators are more efficient than linear regulators, however, they have more electrical noise, added complexity, and are more costly. There are three types of switching regulators: buck converter, a boost converter, and buck & boost converter. Buck converters create a constant output voltage that is lower than the input. They are also known as step-down converters and are like linear voltage regulators.

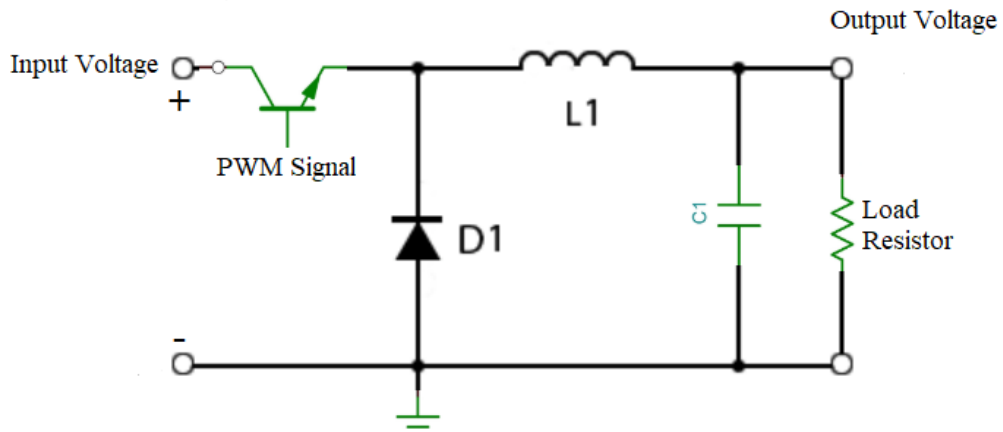

Figure 15: Buck Converter.

Boost converters have a constant output voltage that is larger than the input. Since power must be conserved, the output current is lower than the input. They use the same components as the buck converter but in a different configuration. These regulators are also known as step-up converters.

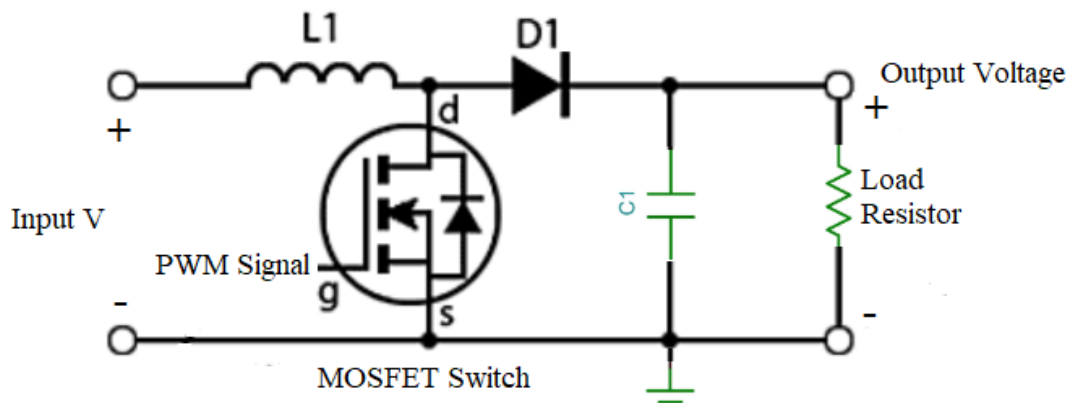

Figure 16: Boost Converter.

Finally, the buck & boost converters can produce constant output voltages that are either higher or lower than the input voltage. These converters have more than one switching component. They are very useful in battery operated devices when the initial charge of the

battery might be more than is needed so the converter steps-down the voltage, but when the battery starts losing its charge it can step-up the voltage to maintain a constant output.

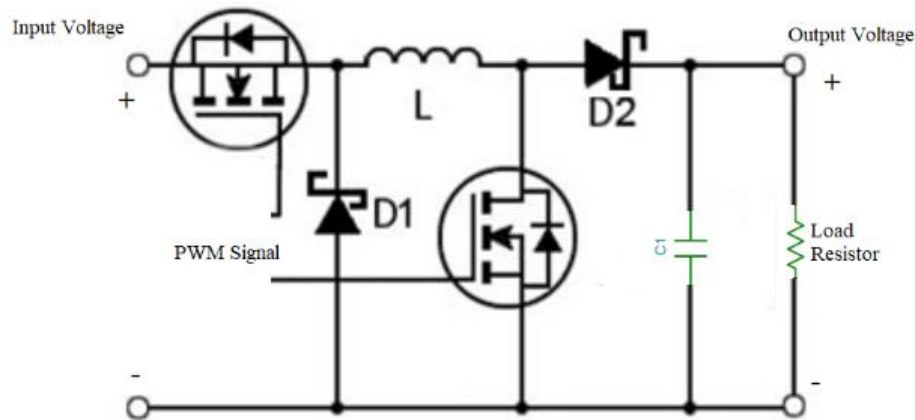

Figure 17: Buck & Boost Converter

3.10 Two-Step Verification

A unique feature of the Baby Buoy pool alarm that the team will be implementing is a two-step verification system. In similar projects researched, it was discovered through user reviews that pool alarms out in the market have a bad reputation for giving out false alarms of an object falling into the pool. To combat this issue, the team is implementing a two-step verification. The two-step verification will eliminate, or reduce, the number of false alarms that the device may capture.

This will be implemented by using a motion sensor above the water's surface and a visual camera below the water. The motion sensor's purpose is to capture any motion within the scope of the device's range of vision. Once the motion detector is set off, it will activate the underwater visuals and send the feed off to the user's mobile device. If the underwater visual picks up an object underneath the water, it will set off the alarm and send out a distress call through a mobile device.

3.10.1 Raspberry Pi Camera v2

The Raspberry Pi camera v2 is an 8 megapixel Sony IMX219 sensor specifically designed for the Raspberry board. This camera can take on images at 1080p30 and videos. This camera is very commonly used in security cameras for image processing and motion detection. It also has the ability to perform time-lapse photography depending on its program settings. The Raspberry Pi camera is an add-on feature for any Raspberry Pi board capable of functioning with 5 volts. This limits the scope of possible microcontrollers that can be used with this camera.

After extensive research, this camera will not be an option for the Baby Buoy project. It is very limited in the options for programmable controllers. It is fair in price standing in the

market for approx \$30, which is a very competitive rate from other cameras. Its high quality resolution though will be a large turn down factor for the final project. With its high resolution, when active, it will be consuming a large portion of current from the microcontroller. This visual option as an underwater camera has been turned down due to its limitations on implementation and current consumption.

3.10.2 MMA8451

The MMA8451 is an accelerometer from xtrinsic. Accelerometers are normally used to detect motion based on its normal pivoting axis. If the module is to be tilted in anyway from a motion, it will send an output signal to the microcontroller that there was a change in pivoting axis, therefore there was motion. The MMA8451 is very economic listed in the market for approximately \$8 dollars. It takes up low current and overall low power, so it would not cause a load of stress on the microcontroller. It will operate through an I2C, which is very common in most microcontrollers, in order to program properly.

For the Baby Buoy project the accelerometer will not be an option. This is due to its mounted housing. Currently, the design of the Baby Buoy will be mounted on the border of a pool. For an accelerometer to function properly we would need to implement a small buoy on the outside of the housing so that it may detect large changes in waves within the pool, to be able to set off the alarm. Although this has been an idea in the past, after careful research it would be smarter to have a mounted housing to be able to eliminate false alerts. With the accelerometer the team would also run the risk of having it be triggered by the current of the pool filter. Due to these factors the MMA8451 will not be a good choice to detect motion within the pool, in order to set an alarm. This device will not be a good choice as a first step verification. Therefore the team will be exploring further options for motion detection.

3.10.3 Passive Infrared Sensor

Passive Infrared (PIR) sensors are very common motion detectors that can be seen through many homes and facilities, in order to catch movement outside of their doors. They are usually implemented in a compact casing that may be mounted on a wall and a small camera for user visuals. With their small compact shape, they are very energy efficient and normally don't wear out. PIR sensors operate with a vision scope that ranges 100 degrees by 70 degrees and up to 20 feet away. They maintain a low power consumption between five volts and 20 volts and ideal at a constant five volts. They are cost effective, at approximately ten dollars per sensor. The PIR sensor works by comparing the differences between heat that is detecting within the sensitivity range. If a human were to walk in front of the sensor it would detect the difference in heat from the surrounding environment. Once it senses the change in environment it would send out an output signal to the main board and alert it off seen motion. Most PIR sensors come with a special edged sphere. This sphere is specially built to amplify the vision of the general sensor. The dome alone is what gives the sensor the range of vision; as it splits the output wave from heat detection.

For the Baby Buoy project the team will be using a PIR sensor as the first step in detecting motion around the perimeter of the pool. Once the PIR sensor detects motion around the

perimeter of the pool, an output signal will be sent out that will commence the second step verification of the underwater visuals. The team believes that the PIR sensor will be a great feature that will keep the cost of the device to be competitive with other pool alarms in the market. The PIR is considered the best choice for above water motion detection.



Figure 18: PIR Sensor [8]

3.10.4 AMG8833

The AMG8833 is a high precision infrared sensor is by Panasonic. The AMG8833 is also known as an array sensor Grid-EYE. The main feature that this camera has to offer is its temperature detection of a 2D area. This camera can collect an array of 64 individual temperatures that are reading over I2C. The AMG8833 is able to detect temperatures ranging from 32 degrees Fahrenheit to 176 degrees Fahrenheit with an accuracy of 4.5 degrees Fahrenheit. The range of scope of visual detection is approximately 23 feet with a max frame rate of 10Hz. This small camera can be used with voltage levels ranging between 3 volts and 5 volts. Its general dimension in stature are 25.8mm x 25.5mm x 6.0mm.

In the Baby Buoy project the AMG8833 will be used to monitor underneath the water's surface. This feature will act as the second step in the two-step verification process for the Baby Buoy pool alarm. Once the PIR sensor , that was described in detail above, is triggered the Grid-EYE will activate commence observing underneath the water's surface. This will be conducting using image processing and computer vision (two subjects that have been covered in detail in sections 3.6 and 3.7). In our software program we will have the AMG8833 programed to pick up images underneath the water. And once infrared image is collected make a decision on if the object is human and in danger or if the object is just a rolling inflatable beach ball. This is two step verification; the user will be able to also monitor the pool through the mobile application. Within the mobile application the user will be able to activate and begin monitoring underneath the water's surface through the AMG8833. This monitoring can be done at anytime around the house, as far as the Wi-Fi network connectivity reaches (approx. 300 feet). The Baby Buoy team believes this

is the best option for the pool alarm, in order to perform a two-step verification as well as monitor underneath the water's surface.

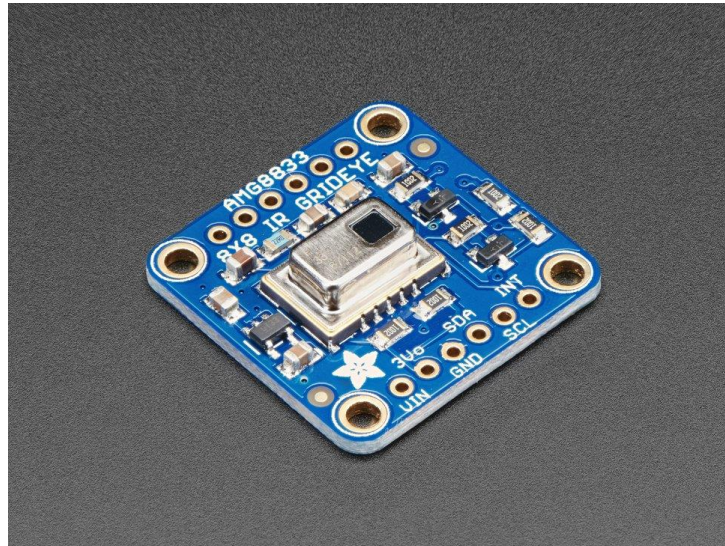

Figure 19: AMG8833 Camera Module [9]

3.11 Software Utilities

In today's resourceful technology, there are numerous tools found on the internet that may be utilized to optimize communication, organization, and design. With the proper use of such tools group projects will endure fewer headaches throughout the development stages of that said project.

3.11.1 Staying Connected

There are various tools that can be used as a platform for communication. Throughout the early stages of development, exchanging thoughts on where to collaborate and organize ourselves is extremely crucial. Essential this would be the foundation of where your brainstorming stage begins. The following are some tools that are being utilized or will be used in the future, of the need of the Baby Buoy project.

3.11.1.1 GroupMe

GroupMe is a messaging application, that is owned by Microsoft. The general purpose of the application is to give users the ability to send group or private messages from their computer or phone using Wi-Fi. With GroupMe, the user has the option of creating an account with them by either the use of Facebook, Microsoft/Skype, or their own personal email address. Through the processes of signing up, the user has the option of syncing their contacts into the application as well as sharing their location to be able to be found by other nearby users with the GroupMe app. A very fun addition being utilizing this application is the preinstalled emojis and GIFs that can brighten conversation that one may have by using the app. A useful tool that comes with the application would also be the ability to create

calendar events, share photos, and videos through a simple user interface. These are very basic features that the application has to offer but if used in the proper manner they may go a very long way.

3.11.1.2 Google Drive

Google Drive is simply a storage cloud for all your personal or private files. This service is a synchronized service that is provided by Google and can be utilized by simply having a Gmail account. In the Google cloud, you can share, view, and edit file with whomever you decide to send an invitation to. Besides sharing documents, Google Drive has built in office applications, such as sheets, docs, and slides that are extremely useful and free to use. By creating a simple Gmail account, you can utilize this tools and be given 15 GB of storage for free. This is a must in your tool box for developers to exercises the ability to share, collaborate, with others in their team, as well as, organize each step of the development process.

3.11.1.3 Github

Github is one of the biggest platforms to help developers solve problems by building software together. After making an account through their website you will have the freedom to store source files of any language and even share them with others. Github is a central location for any and all coding that is done within a project. Whether you are linked in a project with others or working independently, Github contains several tools that are to the user's disposal. One of these tools is the ability to create a separate branch independently from the main source code, therefore to not corrupt files in the middle of editing and testing. Another feature is the ability to keep track of everyone's commits and contributions towards the project. Currently, Github is an open source platform allowing users the freedom to innovate without boundaries, making it a most have in your tool box.

3.11.2 Development Tools

In a world of constant innovation, there are multitudes of tools that can be found online and utilized for free. These tools are created to better assist the developer and create simplicity between user and source code logic. This section will cover the developmental tools that will be used to develop the Baby Buoy system currently or in future development stages.

3.11.2.1 Draw.io

Draw.io is a free tool found online, that may assist you in creating custom charts and diagrams with ease and simplicity. Draw.io provides the ability to share and save your creations in your local drive, dropbox, Onedrive, or Google drive. It contains several features such as templates for UML diagrams, flowcharts, general shapes, and arrows, to help you illustrate the necessary functions. This is a free tool available for anyone without the need to create an account. This tool was very useful in constructing diagrams and flowcharts that are seen throughout this document.

3.11.2.2 Visual Studios

Visual Studio is a dynamic IDE that is powered by Microsoft. Visual studio is free for any individual or collaborative use within small teams. It can compile code written in C#, visual basic, C++, HTML, Javascript and many more coding languages that are built into the platform. It also can download addons onto the platform that will allow Visual Studios to performer compilations of languages such as Python, Ruby, M, and Node.js. With the ability to connect source code with multiple accounts this is a very powerful IDE capable of collaborating with multiple languages through the cyber world.

3.11.2.3 Creately

Creately helps you draw diagrams of all kinds and collaborate with others. It can be easily used to illustrate your ideas, plans and work with your team. Creately can run on your desktop or your browser. Everything is sync via the cloud, so you collaborate with other in real time. Creately has a library of assorted templates that you may choose from to help you begin your diagram. The user interface is very user-friendly and colorful to help beginner navigate through all its features. Creately has a smart AI interface that will predict what type of diagram you are constructing, in order to better assist you in finishing your project in a timely hassle-free manner. This is a paid product but can be used for five free diagrams to be saved on its cloud storage without purchasing one of its packages.

3.11.2.4 Android Studio

Android Studio is the official IDE (Integrated Development Environment) for developing applications for Android operating systems. Android Studio is a free software created by JetBrains IntelliJ that can be used on several different computer operating systems such as Linux, Windows, and macOS. Different team members have different operating systems of choice, which makes it a huge convenience to be able to have this IDE, since mobile application development won't be strained onto only one developer of the team. Applications can be developed in Java, Kotlin, or C++. Being able to develop applications using Java is great, since several team members have experience with that programming language. The team also has experience using Android Studio since previous classes required by the College of Engineering and Computer Science have required a mobile application to be developed throughout the course. This would be more particular to the Computer Engineers of the team.

3.11.2.4.1 Android Studio Features

Android Studio offers various features for developing mobile applications. Considering that it is the official IDE, it means that there is constant support from the creators to make it run smoothly. Constant updates shows that the creators are concerned for the end users, since bugs can be patched with an update. Another feature is the Advanced Code Completion that it offers. The code completion that Android Studio offers for the Java language is exceptional. Code completion essentially completes the code for you depending on what you are trying to do with your code. It knows when a variable has previously been declared, which will allow it to auto complete if chosen based on the first few letters that you type out. Code completion also helps reduce the amount of time used

when typing every letter out. Code completion is also more based on the development of mobile applications, since that it is the main purpose of the IDE.

Navigating through Android Studio is easy once you learn where all the buttons are, and what they do. The UI (User Interface) for Android Studio is very effective for mobile application development since it was built purposely for Android, as opposed to another IDE where the purpose is in being the best all-purpose IDE. Project organization is great since Android Studio creates modules to manage and organize the code modules.

3.11.2.5 EasyEDA

EasyEDA is a browser based electronic computer aided design tool that allows teams to collaborate in the design of board schematics and PCB design. The website has an open source library of components which include pinout of IC components as well as PCB pad and pin mappings for most components. Schematics can be converted to PCB layouts fairly easily with the built-in functionalities. EasyEDA is partnered with an online store for electrical components called LCSC as well as a custom PCB manufacturer by the name JLCPCB. These partnerships make EasyEDA very convenient since components can be selected from the design and bought simultaneously, and once the PCB design is done, it can be sent out for manufacturing, the only thing they will not do is place the components on the PCB, which can be done with a pick-and-place machine or manually soldering.

3.11.2.6 Multisim

Software created by Electronic Workbench, now owned by National Instruments, used for electronic schematic capture and circuit simulation. Multisim is a powerful tool with an extensive library of components and analysis tools. During simulation, the circuit can be probed using digital multimeters and oscilloscopes, the simple interface makes it ideal as an academic aid for students to learn electronics without the need for breadboards and expensive equipment.

3.11.2.7 Eagle CAD

Eagle is an Autodesk software package used to design electronic schematics and PCB layouts. The software has a free package that is available for students. It has a comprehensive library of components to ease the schematic design process and a powerful converting tool to turn the schematic into a PCB design. Eagle has a large community and plenty of online resources to get started, including how-to tutorial videos in youtube among other things. The program is an electronic design automation (EDA) tool much like EasyEDA. However, the paid software is more powerful than EasyEDA and more commonly used in industry.

3.12 Pulse Width Modulation

In the topic of buck and boost converters, the term pulse width modulation (PWM) was used. PWM is a method for generating analog signals from a digital source by precisely regulating when the signal turns on and off. Digital signals are limited to only two discrete

states, on or off, usually 5V for on and 0V for off. Analog signals are continuous and time-varying, they can have any value. The Duty Cycle represent what percentage of time the digital pulse is on during a period, or the inverse of frequency. If a signal is on for 75% of its period, then the duty cycle is 75%, Figure 17 shows other examples of duty cycles.

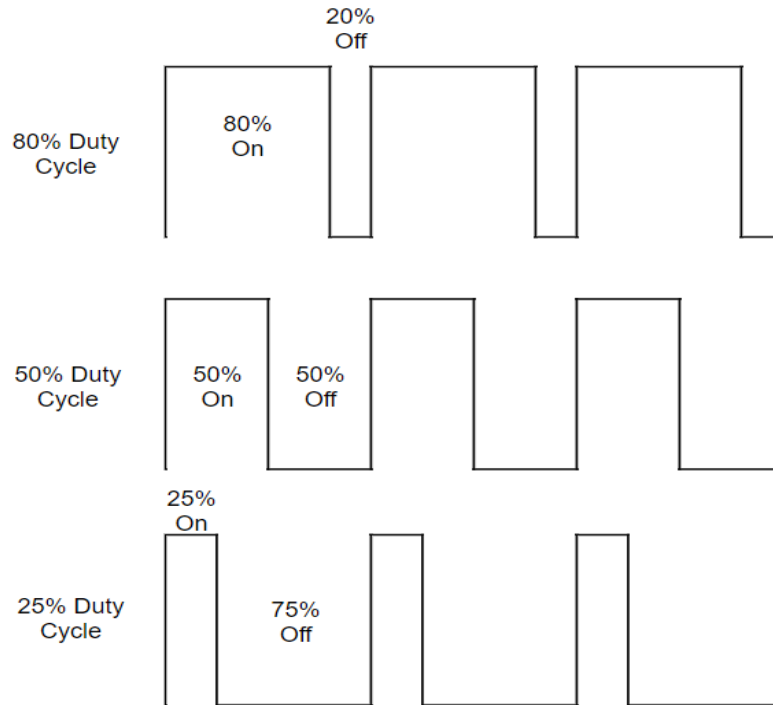

Figure 20: Duty Cycle examples

The brightness of LEDs can be controlled by adjusting the duty cycle of a digital signal, which parallels an analog current adjustment. Pulse width modulation has a variety of uses from servo control, telecommunications, power delivery, audio control, and voltage regulation as previously stated. In modern RC servos, the duty cycle of the pulse determines the angle of rotation, with pulses traveling at 50 Hz or 20 ms. In telecommunications, the pulse width is used to encode the amplitude of transmitted signals.

3.13 Printed Circuit Board

Printed circuit boards (PCB) are a part of every electronic product in the market today. The need for smaller and cheaper electronics devices led the evolution of circuits from point-to-point wiring, to vacuum tubes and relays, and eventually to silicon and integrated circuits on PCB. Printed circuit boards have metal lines, also known as traces, and pads to connect components together in any required configuration. Solder is used to make electrical connections between components and the PCB, it also serves as a strong mechanical adhesive since it is a metal, usually consisting of tin and lead.

The PCB consists of several different layers, including the silkscreen, soldermask, copper, and substrate. The silkscreen is the outermost or top layer, its main purpose is to add

symbols and labels to facilitate assembly and make it easier to understand for other people. This layer is usually white but any color can also be used. The soldermask gives the PCB its color, it is usually green. The purpose of this layer is to insulate the copper traces and expose the pins and pads that will be used for soldering. The copper layer is a foil that is laminated to one or both sides of the substrate depending on whether it is a one sided or double-sided PCB. Currently, it is common for more sophisticated PCB designs to have 8 copper layers or more. The circuit traces and ground are located in this layer, its thickness is commonly 1 ounce of copper per square foot, but it can be made thicker if the device consumes higher power. Finally, the substrate is the core of the PCB, it provides thickness and rigidity. The substrate is most commonly made from FR4 which is a type of fiberglass with a fire-resistant epoxy resin binder, although flexible high temperature plastics such as kapton are also used.

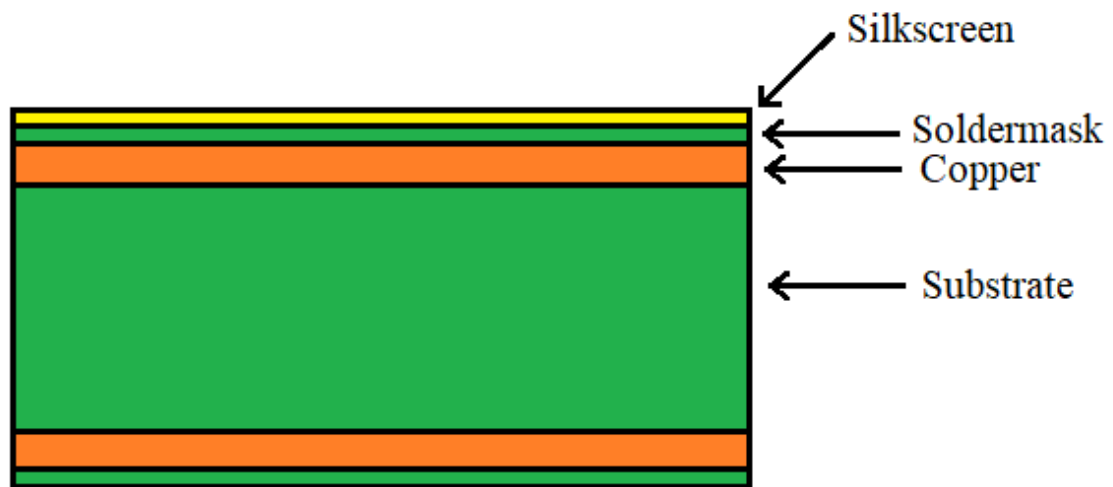

Figure 21: PCB layers.

PCB design requires knowledge of the terminology used to describe the topology of the board. The following list defines these terms.

- **Wave solder** - A soldering technique for through hole components in which the board is passed over a standing wave of molten solder which connects the components to the board.
- **Via** - Holes in a board that allow signals to pass from one layer to another. Sometimes the via is under the soldermask to protect it from unintended soldering, this is called tented vias.
- **V-score** - Is used to tear off boards from a panel, similar to mouse bites. The perimeter of the board is partially cut to make it easy to snap off.
- **Trace** - A path of copper within the board that is used for circuit interconnections, it replaces wires in older circuit designs.
- **Thermal** - Small trace that connects a pad or annular ring to a plane, it is used to allow the connection to reach a high enough temperature for a good solder joint.

- **Surface mount** - Components are soldered to pads on the PCB instead of passing through holes in the board. It is the most common method used to place components on a board.
- **Solder jumper** - Refers to shorting two or more adjacent pins with solder on a PCB. It can be done on purpose to connect pins without the need for wires or new traces, but it can also be an error if too much solder is used on a pin.
- **Solder pot** - A pot containing molten solder, it's used to quickly hand solder boards by dipping them in the pot, creating solder joint on any exposed pads.
- **Solder paste** - Small solder particles are suspended in a gel medium which is applied with the paste stencil. When the paste is heated, reflow occurs and the solder particles melt, serving to connect components to the PCB.
- **Slot** - A hole in a PCB that is not round, they may be plated or not.
- **Reflow** - Refers to melting solder to connect components to PCB pads.
- **Pogo pin** - A tool used to penetrate the soldermask to make temporary connections for testing purposes.
- **Plated through hole** - Is used to connect through hole components or as mounting holes for the PCB. It is a hole with an annular ring that goes through the board.
- **Plane** - Also known as pour, it's a sheet of copper in the board that is defined by borders instead of a path, it is most commonly used for the ground terminal of the PCB.
- **Pick-and-place** - A machine used to place components on the PCB board to solder. It uses suction to hold on to components and places them on the board pads, which are heated so the components are instantly soldered.
- **Paste stencil** - The copper pads on the PCB are covered with solder paste to facilitate soldering of components in the pick-and-place machine. The paste stencil is a mask that goes over the PCB with holes where the pads are to deposit the solder. Stencils are thin metal or plastic sheets.
- **Panel** - A collection of boards in the same substrate that can be broken apart after manufacturing into individual boards. Having a panel of boards is more efficient since automated handling equipment doesn't need to change boards as frequently and it's also easier to handle larger panels.
- **Pad** - The exposed metal on the board that is used to solder components.
- **Mouse bites** - A series of clustered drill hits along a path to create weak spots for separating boards from a panel with multiple copies. The boards can be broken off by hand or with pliers, making sure not to bend the board too much or the traces might be damaged.
- **Finger** - Used to connect two separate circuit boards together. They are exposed metal pads along the edge of the board, commonly seen in GPU units and RAM sticks.
- **Drill hit** - Locations where holes should be drilled in a PCB design. Dull drill bits can result in errors in the drill hits, this is a common issue in manufacturing.
- **DRC** - Stands for design rule check. The design is reviewed using software to make sure there are no trace shorts, incorrect trace thickness, or incorrect hole diameters, among other possible errors.
- **Annular ring** - The ring of conductive material, commonly copper, around a plated through hole in a board.

Some manufacturing requirements to ensure a working PCB include the dimensions of pins, pads, traces and layers in relation with each other. The pad sizes must be 0.010” larger than the finished hole size for vias and 0.014” larger for component holes. Recommended hole sizes are 0.015”, with the minimum allowed size of 0.008”. Copper trace width of 0.005” are recommended with spacing between traces of 0.008”. The minimum silkscreen width is 0.005”. For power circuitry, the trace widths are larger than for logic circuitry, this width is a function of the current going through the traces. The following table relates trace width to maximum current ratings.

Table 4: Guidelines for trace current capacity. Source: Armisted Technologies

Temperature Increase	10 °C	20 °C	30 °C
Width	Maximum Current (A)		
0.010”	1	1.2	1.5
0.015”	1.2	1.3	1.6
0.020”	1.3	1.7	2.4
0.025”	1.7	2.2	2.8
0.030”	1.9	2.5	3.2
0.050”	2.6	3.6	4.4
0.075”	3.5	4.5	6
0.100”	4.2	6	7.5
0.200”	7	10	13
0.250”	8.3	12.3	15

In the case when there is not enough space in the PCB to increase the trace width for a higher current capacity, a common technique is to leave the traces exposed after the solder mask is deposited and add solder to the top of the trace, increasing the trace weight and current carrying capacity. The Baby Buoy will have a PCB design inside the main housing that will include the MCU, battery charging IC, and voltage regulator IC, with all the corresponding passive components and switches for the inputs and outputs as required.

3.13.1 PCB Partitioning

Another important factor of PCB design is the electromagnetic compatibility (EMC), which refers to the ability of the whole electronic system to work with no errors caused by electromagnetic interference (EMI). To prevent or reduce interference, a few design criteria should be followed. The circuit loop must be minimized to prevent it from acting as an

antenna for EMI. Also, only a single reference plane should be applied in a system. If the PCB has both digital and analog signals, or mix-signal, the ground planes should be separated, one for analog, the other for digital, in order to isolate them. Failure to do so will greatly increase EMI and signal crosstalk.

4.0 Design Constraints and Standards

All projects that take on a form of engineering contain certain constraints and limitations that play a role in the completion of the engineering project. These constraints range from being technological, some sort of legal constraint, or even financial. Whichever the case may be, all constraints must be handled appropriately and in a timely manner to ensure success in the development of the project. The following section goes over several design constraints and standards that affect the development of the Baby Buoy.

4.1 Constraints

In the development process of the Baby Buoy project, various design constraints play a role in implementation. Thus, in this section the design constraints will be highlighted of the overall system.

4.1.1 Economic Constraints

The overall cost of development plays a major constraint. The Baby Buoy team will be funding the entire project themselves. This will mean the team will have to conduct extensive research on the part that will be put in the final design of the Baby Buoy. This research is crucial for the fact that the team will not have the freedom to perform trial and error in pursuit of determining which components would best work for the Baby Buoy system. By buying multiple components in afferts to create a trial and error scenario will only increasing the cost of the prototype as well as lead to a financial burden on the team.

The manufacturing cost for the Baby Buoy must also stay as low as possible to be able to compete with other similar products out in the market now. The Baby Buoy must be affordable and for all users in whichever wide group they may pertain to. Keeping the cost low will also help in marketing our product to the ideal user. In an ideal case, the Baby Buoy team would take advantage of having the freedom to test and explore different components in a trial and error scenario. But due to the Financial constraint, the team must find a the finite balance between cost and quality.

4.1.2 Health and Safety Constraints

The teams top priority when developing and designing this product is the health and safety of the end user as well as the Baby Buoy team, when testing commence. The purpose of the Baby Buoy project is to save the lives of children by alert a parent or guardian if there is any child near or in the pool. Therefore, attentive attention is being invested into what the needs to being considered and what needs to be accurate in order to accomplish this safety constraint.

Careful programming and development is taking into action when it comes to the motion sensing and the Wi-Fi connectivity. The Baby Buoy device will contain two types of cameras on board the device. Even with both cameras operating, a lag or lack of programming in the software to advise the camera that there is a child in the perimeter may lead to a life threatening situation. The lack of proper programming may lead to the alarm not sounding or the parent or guardian not being notified with time. This also applies to the

Wi-Fi connectivity of the device. If the camera is detecting motion in the perimeter but the Wi-Fi connectivity is not strong enough to reach the user from 300 feet away or the Wi-Fi has poor connection, these are errors that will lead to life threatening situation.

All the dangers stated above are very much possible if these features fail, but they may also be caused by the faulty hardware. A bad sensor which happens to stop working after installation or faulty wiring with a poor connection may lead to safety hazards. To avoid the described scenario above, the team is being very thorough when it comes to testing the components of the device before installing them on the PCB board. Although, all the components will be aggressively tested before installation, malfunctions will still be a possibility, which is the sour truth of computer components. In attempts to keep the malfunctions in the eyes of the user, data will be collected in the form of logs in order to check on the features in on the device.

Powering the device is also something that the Baby Buoy team is putting up as a high priority. Every component in the device will need power to operate efficiently. Thus, the team is using a lithium battery that is calculated to power all the components as well as solar panels to be able to help the battery and maintain it. For the natural environment of the device, obtaining solar power will not be an issue being that it is built for outdoor use. In general, the team is studying on a library of lithium batteries and solar panels that are in the market today, so to best choose one that would power all components. The Baby Buoy team will practice caution when handling both solar panels and lithium batteries as they both contain hazardous chemicals and materials that are harmful to the human body.

The Baby Buoy device, as implied by the name, involves the monitoring of children. Having the device outside and accessible to the children that the device is monitoring. The housing of the device must be secure and inaccessible to the children. Inside the device there are many small hazardous components and chemicals that may be harmful to small children. This device is to only be operated by adults. To combat this issue the solar panel will be encased in a transparent box outside the pool and small components will be secured in a deionized aluminum frame. Even though these protective measures are put into effect, the device is still to be operated by adults only with caution.

4.1.3 Social Constraints

The purpose of the Baby Buoy is to increase the safety surrounding the average user's home pool. In order to achieve this the team is striving to keep the cost of the product low, so that it may be available to many users, rather than a select group of users. Another social constraint, is the ease of device installation. This is being put into consideration when it comes to the designing and testing of the device. Being that the device has many built in features, such as Wi-Fi connectivity and motion detection, when it comes to the installation method, the team is striving to make it very friendly to the ideal user.

4.1.4 Sustainability Constraints

The team is envisioning the device to sustain a life span of up to seven days without recharging the battery. The sustainability constraint is derived from the harsh environments that the device will be placed under once finalized.

The Baby Buoy device will need to be able to withstand extremely hot and cold environments. During the warmer climates the components and general device itself, must be able to withstand the warm southern climates of the United States, and the cold climates of the northern states. This will be very well thought out by the team, as the device will exhibit an aluminum frame in order to protect the components inside, such as the cameras and MCU. After careful research, the team has come to terms that the pool alarm will sustain an ideal temperature to maintain all the component healthy by having a portion of the device submerged in water. This will automatically keep the aluminum frame cool throughout the summer seasons. For the winter months, the team has been very specific with the selection of components and has made sure that all components that will be within the housing, may withstand extremely harsh cold environments. Having all electrical components inside the aluminum frame and also constructing a see through casing for the solar panels will guarantee protection from other unforeseen climate changes such as strong winds, rain and snow.

Besides the alternative climate changes throughout the fiscal year, the device will also need to be 100% waterproof. To ensure this, the team will be implementing waterproof electrical wiring sockets. The sockets will prevent water from coming into the unit at all cost and ensure a dry environment for all the electronics.

4.1.5 Time Constraints

The time constraints might be the most important constraint. The Baby Buoy team is given a period of approximately eight months to accomplish the desired product. The time constraint is the driving factor to many design decisions. The team is given till the end of Senior Design 2, two whole semesters, in order to accomplish a product. The team must take into consideration this time and keep the design of the product optimal but within scope of the time frame. There are various features that may be implemented into the final Baby Buoy product, but they would be considered out of scope. Thus, the team is not considering these features at this time.

To achieve maximum performance from all team members, a schedule has been created to take on the two semester time constraint. In the process of managing time, the construction of the PCB is being considered by the Baby Buoy team. It is to the team's knowledge that the PCB requires excessive attention to detail. Once the PCB is constructed it must be shipped off for testing, which may lead to a redesign of the PCB and further testing. The teams schedule can be seen in the the administrative section under project milestones.

4.1.6 Presentation Constraints

The Baby Buoy team is limited when it comes to showcasing the product and testing. This is due to the fact that the system is developed for outdoor use, specifically in a swimming pools. To showcase or device the Baby Buoy team is planning on having several recorded test results, that will be conducted outside of campus.

The team has reached out to friends and neighbors that are willing to lend the team time to access their property in order to test the prototype. The access is limited due to it being at the teams' friends and/or neighbors convenience. An advantage in this case is having the possibility of testing our device against several different size pools of different dimensions and lengths. In this scenario, the team will be able to adjust programming to be suitable for multiple pools which is more suitable for a real world user, being that not all people have the same shape swimming pool or size.

4.1.7 Manufacturability Constraints

When analysing the components that are taking part in the final product for the Baby Buoy device the team is ensuring that the component chosen have been in the market for some time and that it is not an exclusive model. This will pose a manufacturing constraint. Every piece that has been ordered to take part in the final product has been check for the number of units in stock that are available and how long that it has been available to the general consumer. This is placed at a high priority because the team must insure that they have some sort of insurance when it comes to relaying on parts from manufacturer. Shipping and availibel part will pay a toll our our timeline to complete the project if the manufacturing constraint is not put into high priority.

4.2 Standards

In the following section, several hardware and software standards are brought to light for better examination. While these standards are analysed, there will also be discussion on how it relates to our project. In this section, discussion on general safety procedures and concerns will be touched on to further ensure the safety of the group in their specific design implementation.

4.2.1 IPC PCB Standards

The Association Connecting Electronics Industries, or IPC, is a trade association determined to standardize the manufacturing process of electronic equipment. This association has published many standards that are used by commercial PCB manufacturers to ensure reliability in their products and uniformity within the market. The IPC-2221 is the generic standard on printed board design that establishes the requirements for component mounting and interconnecting structures. Other standards include IPC-2615, which covers printed board dimensions and tolerances. IPC-ET-652 for guidelines and requirements for electrical testing of PCB with no components. IPC-A-600 describes the acceptability of printed boards in inspection settings. IPC-A-610 for acceptability of electronic assemblies. Some material specification standards include IPC-4562 for metal foil for printed wiring applications and IPC-4202 for flexible base dielectrics for use in flexible printed circuits. IPC standards range from general topics to design specifications, materials, performance, and inspections.

The Institute for Printed Circuits was originally founded by six individual printed circuit board manufacturers but in 1957. After 20 years, in 1977 the six manufactures officially changed the name of the institution to the Institute for Interconnecting and Packaging

Electronic Circuits (IPC). Since then the institution has been able to publish several standards for when it comes to building a circuit from scratch. The IPC has gone into depth on design specifications, material specifications, performance and inspection documents, flex assembly and materials standards, and general documentation. It is recommended to use the IPC standards when it comes to building your own custom circuit.

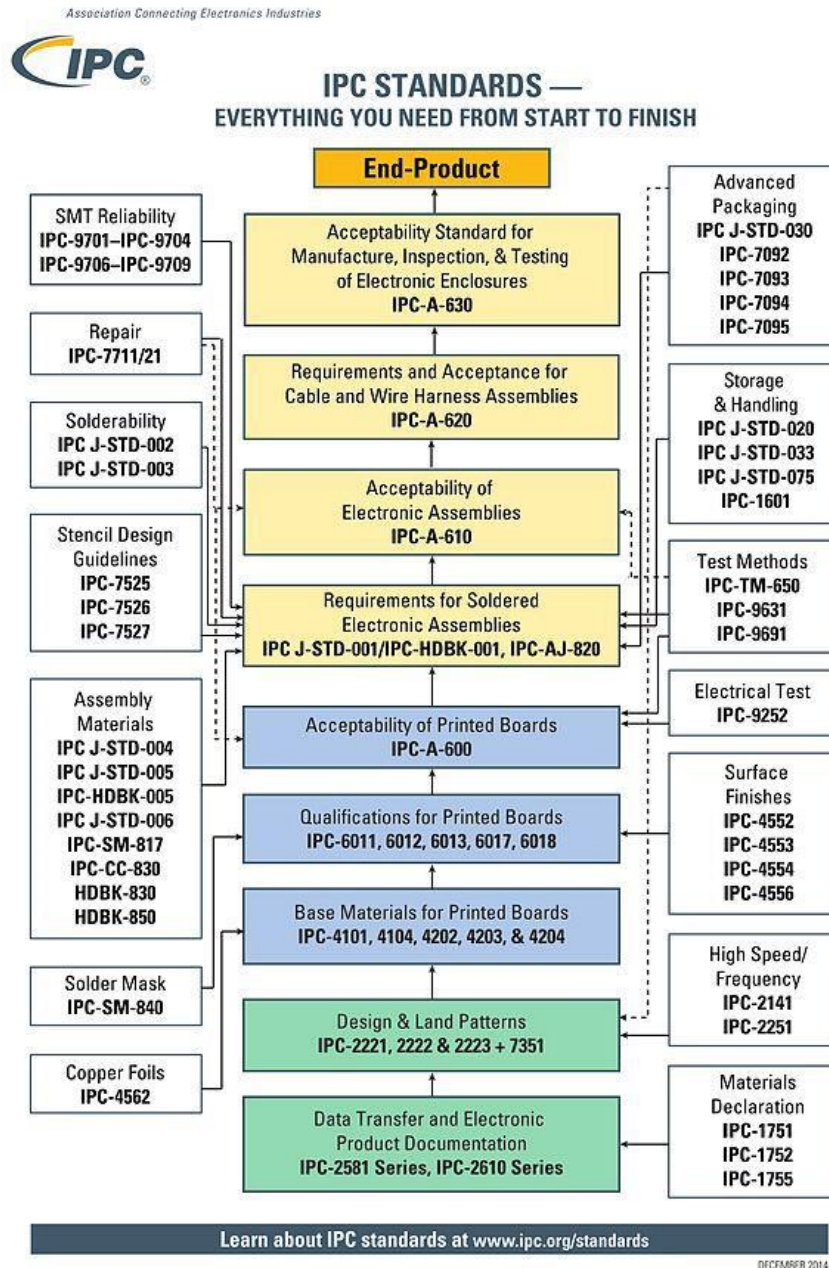

Figure 22: IPC Standards [10]

In the Baby Buoy project, the team will be manufacturing their own PCB board. In the process of doing gather the elements and collecting research, it is important for the team to follow several guidelines that are stated within the IPC standards. As illustrated in the

image above the IPC standards are step by step documents that thoroughly go into detail on what are some of the expectation for getting a PCB to be checked out properly, how to add components through soldering, what type of flux to use to create the best joint. Throughout the building process. The team will be going back through the IPC standards to insure an accurate and efficient board for the Baby Buoy.

4.2.2 IEC 60950-1

The safety of information technology equipment standard is applicable to mains, battery-powered equipment and office electronic devices with rated voltages under 600V. Its main purpose is to prevent hazards such as fire, electric shock, and mechanical instability. It divides equipment into three main classes. Class 1 equipment protects from shock by basic insulation and protective earth grounding. In other words, if the insulation of a conductive segment fails for any reason, the conductor is also connected to a protective earth conductor. Class 2 equipment requires no ground for protection since it uses double or reinforced insulation. Finally, Class 3 equipment operates from a safety extra low voltage (SELV) supply circuit, which inherently protects from electric shock since the equipment is unable to generate a hazardous voltage. Some definitions are required for the complete understanding of the standard:

- **Hazardous Voltage:** Any voltage over 42.2 VAC or 60 VDC without a limited current circuit
- **Extra-Low Voltage (ELV):** A voltage in a secondary circuit under 42.2 VAC or 60 VDC that is separated from a hazardous voltage by at least insulation.
- **Safety Extra-Low Voltage Circuit (SELV):** A secondary circuit unable to reach a hazardous voltage. SELV circuits must be separated from hazardous voltages by two levels of protection such as double insulation.
- **Limited Current Circuits:** Are designed to output safe currents even in the case of shorts or any fault conditions. For frequencies lower than 1 kHz, the steady state current cannot surpass 0.7 mA AC or 2 mA DC. For higher frequencies, the 0.7 mA limit is multiplied by the frequency in kHz without exceeding 70 mA.
- **Limited Power Source (LPS):** Designed with a set output voltage, current, power, and short circuit current limit.

4.2.3 IEC 60529

The International Electrotechnical Commission (IEC) 60529 is a standard that goes over what would classify an object to be protected from environmental elements. This standard is also known as the Ingress Protection Marking. These standard rates a device based on the degree of protection from dust, intrusion, accidental contact, and water. The Ingress Protection (IP) has its own grading scale in order to classify devices that are claiming to be protected for a environmental element.

In the grading scale format is as follows “IP##”. The “IP” would stand for it being officially graded by the Ingress Protection. The first number or digit would tell the user the intensity of the object’s protection from a solid surface. The second number is how resistant the device is to water. The higher the rating the more protected the device is. The Ingress

Protection goes through aggressive and extensive testing to scale the protection of devices. No other company can mimic what they do, therefore no other company can create their own grading scale to classify the protection of their own device or that of others.

IP (Ingress Protection) Ratings Guide













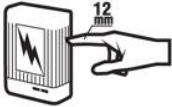

SOLIDS		WATER	
1	 <p>Protected against a solid object greater than 50 mm such as a hand.</p>	1	 <p>Protected against vertically falling drops of water. Limited ingress permitted.</p>
2	 <p>Protected against a solid object greater than 12.5 mm such as a finger.</p>	2	 <p>Protected against vertically falling drops of water with enclosure tilted up to 15 degrees from the vertical. Limited ingress permitted.</p>
3	 <p>Protected against a solid object greater than 2.5 mm such as a screwdriver.</p>	3	 <p>Protected against sprays of water up to 60 degrees from the vertical. Limited ingress permitted for three minutes.</p>
4	 <p>Protected against a solid object greater than 1 mm such as a wire.</p>	4	 <p>Protected against water splashed from all directions. Limited ingress permitted.</p>
5	 <p>Dust Protected. Limited ingress of dust permitted. Will not interfere with operation of the equipment. Two to eight hours.</p>	5	 <p>Protected against jets of water. Limited ingress permitted.</p>
6	 <p>Dust tight. No ingress of dust. Two to eight hours.</p>	6	 <p>Water from heavy seas or water projected in powerful jets shall not enter the enclosure in harmful quantities.</p>
<p>Rating Example:</p> <p>IP65</p> <p>INGRESS PROTECTION</p>		7	 <p>Protection against the effects of immersion in water between 15 cm and 1 m for 30 minutes.</p>
		8	 <p>Protection against the effects of immersion in water under pressure for long periods.</p>

Figure 23: IP Rating Chart [11]

The highest level of waterproof that the IP has to offer is IPX9K which means that the tested device is able to resist high-pressures and, high temperatures sprays at close range. This high rating is very rarely used in day to day market devices. A more commonly seen rating would be the IPX8, which is more commonly used in modern day technology such

as mobile phones. This rating states that the device is capable of being submerged under water for more than one meter. The exact depth of testing can be changed based on the manufacture needs.

For the Baby Buoy pool alarm the team will be attempting to accomplish a water-resistant rating of IPX4. This classification shows that the product is water resistant from any direction. Due to the fact the team does not plan on making this project a marketable device we are setting this rating as a goal. From lack of time and budget the team will not be reaching out to contact with the International Electrotechnical Commission to ask for and IP marking. Although the IP marking of certified protection will not be received from our device, we will still be attempting to achieve waterproofing from any direction.

4.2.4 Frequency Band Standards

This section covers the various frequency bands available for wireless internet signals, particularly the 2.4 GHz and 5 GHz frequencies using the 802.11n standard.

4.2.4.1 The 2.4 GHz Band

The 2.4 GHz frequency band is the most common frequency available. It has become a well establish standard, given its popularity and low cost. The 2.4 GHz frequency has certain limitations that the 5 GHz doesn't have. 2.4 GHz frequency is overcrowded, providing more interference from external devices that use the same 2.4 GHz frequency such as cordless phones and microwaves. This reduces the theoretical internet speeds that the frequency can provide, while also negatively impacting a users router and access points. Below is a table of theoretical vs actual distance and internet speeds using the 2.4 GHz frequency.

Table 5: Theoretical vs Actual Distance and Internet Speeds with 2.4 GHz frequency

Theoretical Distance	Actual Distance	Theoretical Internet Speeds	Actual Internet Speeds	% Increase or Decrease from Theoretical to Actual
820 ft	410 ft	300 Mbps	150 Mbps	50% decrease for distance and internet speeds

Table 1 shows the theoretical and actual distance and internet speeds that the 2.4 GHz frequency should provide using the 802.11n standard. It can be seen that there is about a 50% decrease from the theoretical numbers and the actual numbers. Theoretical distance goes from 810 ft to 410 ft, while theoretical internet speeds goes from 300 Mbps to 150 Mbps. 2.4 GHz is more susceptible to interference while providing lower data rates, but it is much better at covering large areas of a home or store since it is great at penetrating solid

objects. The integrated chip of the Raspberry Pi 3 B using a 2.4 GHz frequency with the 802.11n standard. This means that we can get up to 410 ft from where the Baby Buoy is located, to the router inside the home.

4.2.4.2 The 5 GHz Band

The 5 GHz frequency band is far less common in homes. Unless you decide that you want to upgrade your internet speeds from the ISP (Internet Service Provider), it is difficult to justify upgrading from a 2.4 GHz router to a dual band router that provides 2.4 GHz and 5 GHz frequencies. Although the 5 GHz provides clearer signals and more channels that can be combined for higher speeds, it lacks in area coverage. Below is a table of theoretical vs actual distance and internet speeds using the 5 GHz frequency.

Table 6: Theoretical vs Actual Distance and Internet Speeds with 5 GHz frequency

Theoretical Distance	Actual Distance	Theoretical Internet Speeds	Actual Internet Speeds	% Increase or Decrease from Theoretical to Actual
460 ft	230 ft	900 Mbps	450 Mbps	50% decrease for distance and internet speeds

Table 2 shows the theoretical and actual distance and internet speeds provided by the 5 GHz frequency, using the 802.11n standard. The 5 GHz frequency also has a 50% decrease for theoretical vs actual distance and internet speeds. Theoretical distance goes from 460 ft to 230 ft, while theoretical internet speeds goes from 900 Mbps to 450 Mbps. Due to the lack in distance that a router can provide using the 802.11n, it is hard to justify needing a 5 GHz frequency band router where we won't need the actual internet speeds that it can provide. It should also be noted that the Raspberry Pi 3 B is unable to connect to the 5 GHz frequency due to the limitations of the BMC43438 chip.

4.2.5 Lead Solder Safety

The Baby Buoy Team is expecting to use a high purity alloy such as Sn63Pb37, which is composed of 63 percent tin and 37 percent lead. The solder must be high priority so that the solder joint may be properly joined with the board. The use of lead and lead byproducts poses a danger to the human body. This is well known from the continuous studies of modern science, and therefore require cautions actions when working with lead. Lead poses numerous chronic health effects due to its neurotoxic composition. Some of these side effect include (but are not limited to), muscle and joint pain, concentration problems, digestive problems, reproduction problems, and many more. Therefore, the Baby Buoy team will take the precautionary steps when it comes to handling lead when soldering.

When it comes to soldering in general, one of the first dangers comes from the soldering iron. In order to solder, the soldering iron must be approximately 750 degrees Fahrenheit to melt and manipulate the solder paste. With such extreme temperatures, the first danger comes from possibility of getting burnt. Therefore, when handling the soldering iron it is crucial that the team handle the iron with respect and caution. This may be practiced by soldering little bits at a time and having the iron only out if needed. If not needed, to have it be placed in the cradle and far from human touch. Throughout the building of the PCB board there will be minimal human interaction with the iron, how there are many components that will be placed on the board using a pick and place machine and then heating the items into place through an oven. Another instance that is common to occur is the product coming off the line, such as a misaligned part. In order to fix this issue, hand soldering will be the resolution.

There are various factors that must be placed into perspective when it comes to handling anything that may contain lead. The first and utmost important is the user's health. As stated in the beginning of this section the dangers and side effects of lead have been well documented in the scientific community. However, based on these documents, there are numerous applications, which includes ours, that lead will not necessarily pose a threat to human health. It would take a large amount of lead to be ingested so that it poses a threat to the human body. How the handling of lead will still occur the team must obey the RoHS compliance, which will be further touched on in section 4.2.6. The RoHS Directive states that there are certain elements and chemicals that must be handled in accordance to specific guidelines if that said product is being shipped abroad. In the case of our product this will not be something of concern now, but it may be seen as an issue in a future tense. Currently, the 37 percent of lead is not decent for what we are attempting to create. Being that is at a lower percentage it is easier to manipulate and work with when making the joints. Soldering is very precise when it comes to the temperature gradient each paste may need a Fahrenheit in order to blend well. With this solder that will not be an issue. The solder the team plans on using is very friendly and easy to overcome. Although it contains a dominant portion of tin, it is found it work well with small projects as this one.

Another concern that comes from soldering is the solder fumes when working with lead. At Carnegie Mellon University, it has been documented that safety precautions for these fumes must not be taken lightly. The documents at Carnegie Mellon University state that when soldering it would be advised to solder in a well-ventilated area or at least work under an exhaust fan of some sort. They also advise in wearing protective attire when soldering in the lab, this includes and is not limited to closed toe shoes, eyewear, and a mask. When certain parts of the product are being cooked in the heating oven, the fumes will not pose a threat, as the oven is equipped with an exhaust fan built in. The use of safety equipment is still advised while the lab is in use.

As a general summary when taking on project that involves soldering in some way there are specific safety precautionary steps that must be followed. In this paragraph, there will be discussion of these said safety procedures. To begin when handling lead there will always be the production of fumes from the flux that contains rosin. To combat this issue, one must be in a well-ventilated area whether it is an open area, or the area contains

equipment such as an exhaust fan. A good example of such an area would be the UCF TI lab, which is a very open and even is equipped with a soldering station that gives good ventilation. It is also very important to never touch the soldering iron when heated as it may cause severe burns. A soldering iron may reach heat indexes more than 750 degrees Fahrenheit. Therefore, it is critical to ensure that the iron is unplugged and on a stable surface, given that the cradle may easily fall and leaving the iron plugged may lead to unforeseen dangers. While a member is using the lab, it is critical that they are following lab safety wear protocols. This includes and is not limited to wearing eyewear and closed toe shoes. It is also important to wash your hands thoroughly after the use of the soldering iron to eliminate any chances of lead exposure through the hands. Although it has not been discussed in thorough detail in this passage it is of utmost important to never solder when the circuit is live. One must insure that the circuit is not plugged to any sort of power source when soldering. This is done for several reason. One being the safety of the parts on the board and the safety of the user, by avoiding electrocution.

With any type of soldering there will be waste. In the case of soldering with lead there will be waste created that must be disposed of properly. This waste will be packaged in a metal container and properly labeled as hazardous waste and later properly disposed of. This is done in efforts to avoid having any remains of lead go into landfills which is very harmful to the environment. In the UCF IT lab there are dross which are used to dispose of any waste that is produced by soldering with lead. The UCF EHS also provides specific labels that are to the student disposal so that they may properly label the waste they are disposing.

If the statements above are followed properly it will insure safety in the lab environment when handling lead and soldering. Any further question in regards to handling and disposing of waste may be answered by contacting the Environmental Health and Safety (EHS) at UCF, phone number (407) 823-6300.

4.2.6 RoHS Compliance

RoHS, stands for the Restriction of Hazardous Substances Directive. Short for the restriction of use of certain hazardous substances in various electrical and electronic components. This Directive was adopted in February 2003 by the European Union. The RoHS lists approximately ten substances that are to be limited. These ten items being: mercury, lead, cadmium, polybrominated biphenyls, polybrominated diphenyl ether, bis(2-ethylhexyl) phthalate, butyl benzyl phthalate, dibutyl phthalate, hexavalent chromium, diisobutyl phthalate. RoHS is associated with WEEE, which is the Waste Electrical and Electronic Equipment Directive. WEEE main purpose is to set the standards on the collection, recycling, and recovery standards for various electronic goods. Their intentions are to remove harmful substances, such as lead, from electronic devices. The RoHS is not required to contain special stickers to ensure that the order is compliant under the RoHS regulations, however they do require special restriction when it involves shipping to various locations abroad.

The only concern that the Baby Buoy team has from the substances that the RoHS covers would be Lead. Lead is often found in solder paste. Having that the team will be constructing our individual PCB soldering will be occurring. Therefore, the team will be

RoHS compliant. Based on the specifications of RoHS 1 < 1000 parts/millions of concentrations must be maintained over the board at all times to ensure compliance. A very common alternative to lead would be a 98 percent tin solder, but tint does not produce a high-quality solder joint and is more likely to be rejected in examination. Therefore, the team will be compiling with the RoHS regulation when it comes to soldering the PCB together.

5.0 Design

After conducting extensive research on several different products and material on hardware and software features that are relevant toward the Baby Buoy, the following section goes into specifics on components that have been selected. All selections were made with the requirement and specifications in mind. Components that are shown and described below were researched to be the best choice for the Baby Buoy based on affordability and simplicity of design.

5.1 Hardware Design

The Baby Buoy will consist of two main bodies, the solar cell housing and the main housing. The solar cell housing will be made of clear plexiglass to let light through to power the cells. This housing will also include the buzzer alarm to help it propagate sound further. Furthermore, it will act as a counterweight to keep the main housing suspended in the water. An articulated arm will be used to connect the two bodies together, this arm will make it possible to adjust the main housing height so half of it is submerged in the pool. This is done so that the IR emitter/receiver can stay above water while the motion tracking camera is submerged. The articulated arm used for this project is shown in Figure 24.



Figure 24: Articulated arm produced by CAMVATE.

The main housing contains the PCB, PIR sensor, camera, battery pack, thermal sensor. The main housing is divided into three parts: the body, the top cap, and the bottom cap. Figure 26 depicts the main housing in detail. The body is a cylinder 150mm high with an inner diameter of 60mm, it has two acrylic windows 1" in diameter for the PIR system and camera. The acrylic windows are held by PVC threaded sights shown in the figure below.

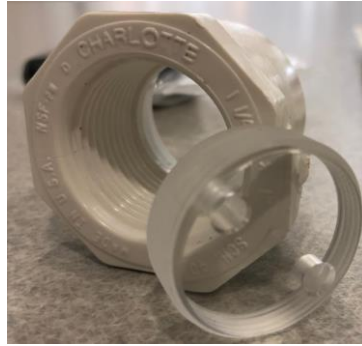

Figure 25: PVC Window holder

The bottom cap is mainly used for easy access to the body from the lower side, it also has a small hole for the thermal sensor to measure the temperature of the pool water. Silicon is used to seal the hole behind the sensor to prevent water leaking inside the housing. The top cap has a threaded hole to secure the articulated arm to the main housing, it also has a hole to pass wires to the solar cell housing. All three components of the main housing are made of anodized aluminum to help prevent corrosion. Each cap is secured to the body by six 3mm screws, there is also a standard 2.625" neoprene O-ring to keep the caps waterproof. The O-ring groove was designed to have a width 20% greater and a height 20% smaller than the ring's cross sectional diameter to ensure a good seal.



Figure 26: Main housing body and caps.

Since the wire passing from the solar cell housing to the main housing must be kept waterproof as well, cable glands are used. Cable glands hold on to wires by compressing them from all directions, creating tight seals. Figure 27 gives an example of what a cable gland looks like. The wire used between the two housings will need to deliver power from

the solar panels down to the voltage regulator in the control and also feed power to the buzzer alarm system, for this reason, a four-wire cable will be used. Two wires to deliver power from the cells and the other two for the buzzer. Since the current will not exceed 800 mA from the solar cells and the cable length will be less than half a meter, a small gage can be used safely, a 20 AWG wire will be used for this project to keep a high margin of safety.



Figure 27: Cable Gland [12]

An aluminum rod is secured to the bottom of the solar cell housing which protrudes out into the pool, the end of this rod has a threaded hole for the articulated arm that holds the main housing. The solar cell housing has four rubber legs to keep it from making contact with the ground and to prevent it from slipping on wet surfaces. The Baby Buoy is a compact system that can be removed at any time from the side of the pool, it is not attached with clamps or screws, only the weight of the solar cell housing. Figure 28 depicts the whole Baby Buoy assembly. The solar cell housing dimensions will be 508x229x130mm and will contain two 165x135mm solar cells.

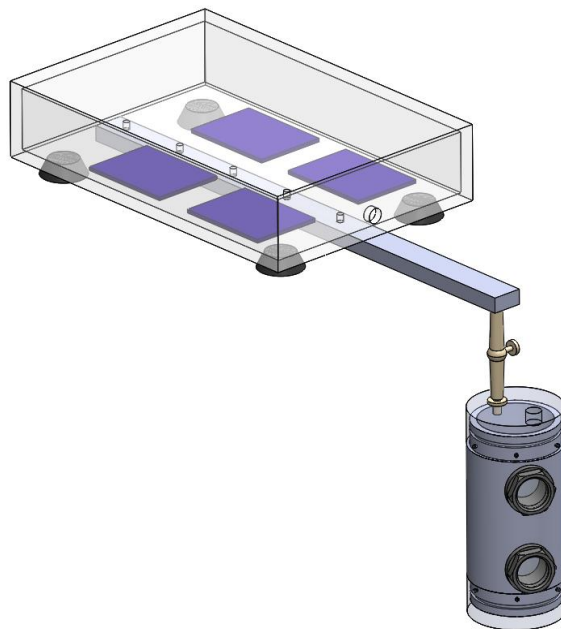

Figure 28: The Baby Buoy full assembly.

5.2 Battery Selection

The Baby Buoy will require a battery capable of powering a microcontroller, camera, WiFi module, PIR sensor, and a piezo buzzer alarm system. The microcontroller selected for the design is the ATmega644 which has a power consumption of 0.15 mA at 5 V. WiFi modules range from 150-360 mA depending on how much data is transmitted. The camera used for this project is the AMG8833, which consumes roughly 4.5 mA at 5 V. The PIR selected for this project is the HC-SR501 system, which requires 65 mA to operate. Finally, the piezo buzzer has a voltage range between 3-24 V and current consumption of 20 mA. At full use, the Baby Buoy would have a maximum load of about 450 mA, which means the battery must have a large capacity and discharge rate. However, most systems will be idle the majority of the time. The camera will only turn on when the PIR sensor detects motion above the water. The WiFi module will turn on to stream video to the app once the camera detects movement under the water, the piezo alarm will sound at that time as well. Considering that only the microcontroller and PIR will be on most of the time, a more realistic power consumption would be in the range of 66 mA.

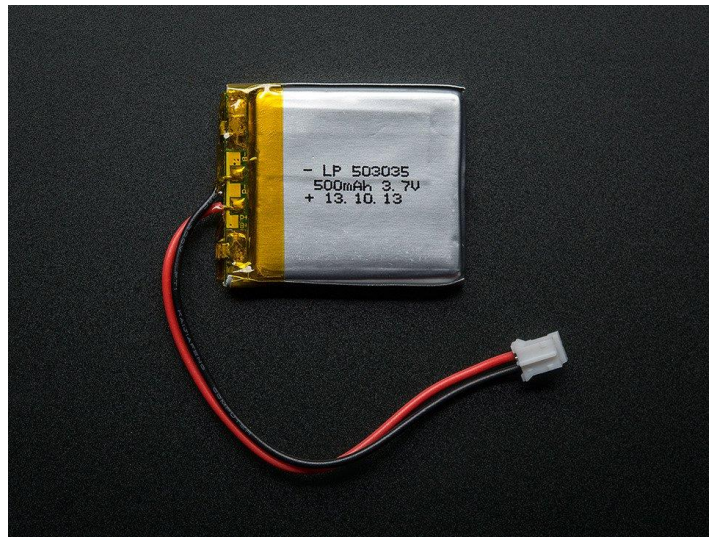

Figure 29: 5000 mAh 3.7V Li-Po battery used. [13]

The Raspberry Pi used for testing has many added functionalities and modules that will not be present in the final design, assuming a low power MCU and efficient power management, the Baby Buoy will consume roughly 100 mA. Since the battery will be charged by solar cells, the Baby Buoy must run on battery power alone during night time, dusk, and twilight, when light intensity is not enough to power the device. Since peak sun-hours are typically between 9AM to 5PM, the device will run on battery for 16 hours out of the day, at 100 mA, the battery capacity must be at least 1600 mAh. The battery must also be impervious to the memory effect since charging will occur irregularly, disregarding the current charge. Finally, the battery must be compact, the Baby Buoy's main body has a width of 60mm and a length of about 80mm for battery space. Since the battery must have a large energy density, high discharge rate, and immunity to the memory effect, a Lithium-Ion or Lithium-Ion Polymer battery was selected. After some research, the

Adafruit 328 battery was chosen, this Li-Po battery has a capacity of 5000 mAh and nominal voltage of 3.7V. The battery dimensions are 59 x 54 x 11mm. With this battery the device should be able to run for several days without solar assistance.

5.3 Electrical Design

The Baby Buoy will run on 5V DC to operate the microcontroller and all other components. The PIR sensor and piezo buzzer can operate at a range of different voltages but they will be operated at 5V to keep the voltage consistent across the whole system. The current requirements of the microcontroller and inputs/outputs will be roughly 66 mA, but when the camera is activated from idle mode, processing power will increase and the current consumption will be around 71 mA. The solar array will be designed to operate the system up to this point, when the camera picks up movement and activates the WiFi module and piezo alarm, the current load will approach 450 mA at 5V, which will be too much for a compact solar array to handle. The Li-Po battery will take over at maximum load operation and at night time when the solar cells are not producing power. Safety is another reason to use the battery back-up when the system is at maximum load, which is when a potential emergency is taking place. Since the solar cells depend on light intensity, even if the solar array was rated for over 500 mA, if the sun conditions were not preferable, the array might not be able to produce enough current during an emergency, for this reason the battery is used.



Figure 30: AMX3d 165mm x 135 mm 6.0V 600mA solar cell.

Solar cells are available in a variety of voltage and current ratings, for this project, the solar array must be able to produce more than 5V and 500 mA. The company AMX3d sells small

165mm by 135mm solar cells that produce 6.0V and 600 mA, these cells are cheap and can be arranged in series or parallel to adjust the output to the desired values. Figure 30 shows the construction of these cells. For the Baby Buoy, two of these cells will be used in parallel to increase the current to 1200mA, providing a small safety margin from the desired values. The solar array output will power the battery charger and go into a voltage regulator before fueling the rest of the system. The battery charger will have to charge the 5000 mAh battery at 625 mA if it is assumed that a full charge will be achieved in 8 hours during peak sun exposure to the solar cells. After extensive research, TI's BQ21040 single input, single cell Li-Po battery charger IC was chosen. The charging current of this IC is programmable and can reach 800 mA, but 650 mA was selected by using a calibration resistor set to 820 Ω . The input voltage to the IC according to its datasheet can vary wildly from -0.3V to 30V which is perfect for a solar cell power supply that changes voltage throughout the day. The maximum input current rating is 1.25A, more than the maximum output of the cells. The voltage regulator will have to step-down the 6V input to 5V when the solar cells are at maximum output. However, the regulator will also have to step-up the voltage when the cells are not producing enough voltage and when the 3.7V battery is powering the system. Since the regulator must increase and decrease the input voltage, a buck & boost converter will be used. TI's TPS6302 buck-boost converter was chosen as the voltage regulator because of its high output current needed for the Wi-Fi module, camera, and alarm. Also, it has a max input voltage range between -0.3V and 7V.

The power supply to the voltage regulator will have to be switched depending on the time of day when the solar cells stop producing as much voltage as the battery. The output of each power supply will also have a passive switch such as a diode to prevent power from the solar cells to enter directly into the battery through the voltage regulator and vice versa. Both the switching of power supply sources and blocking of reverse currents can be achieved using Schottky diodes. These diodes are preferable because of their low voltage drop compared to silicon diodes and faster switching speeds. After some research, the 1N5822 Schottky diodes were chosen for the design due to their large current capacity of 3A to have a large margin of safety.



Figure 31: 1N5822 Schottky diodes

The power supplies going into the voltage regulator were simulated using Multisim, a multimeter was placed in place of the voltage regulator to see when the power supply switch occurred, a variable voltage source was used to simulate the solar cell array, Figure 32 shows when the solar cells are at max capacity, the multimeter determines that the voltage is coming from the solar array.

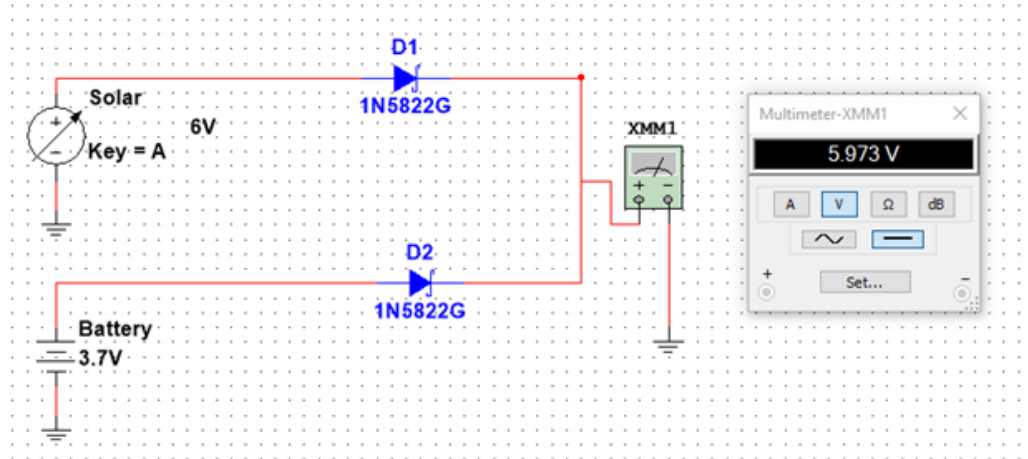

Figure 32: Solar cell voltage higher than battery voltage.

Next, the variable voltage was dropped below the battery voltage, Figure 33 shows that the voltage source is now the battery. The Schottky diodes were capable of changing power supplies when necessary without the need of any programming.

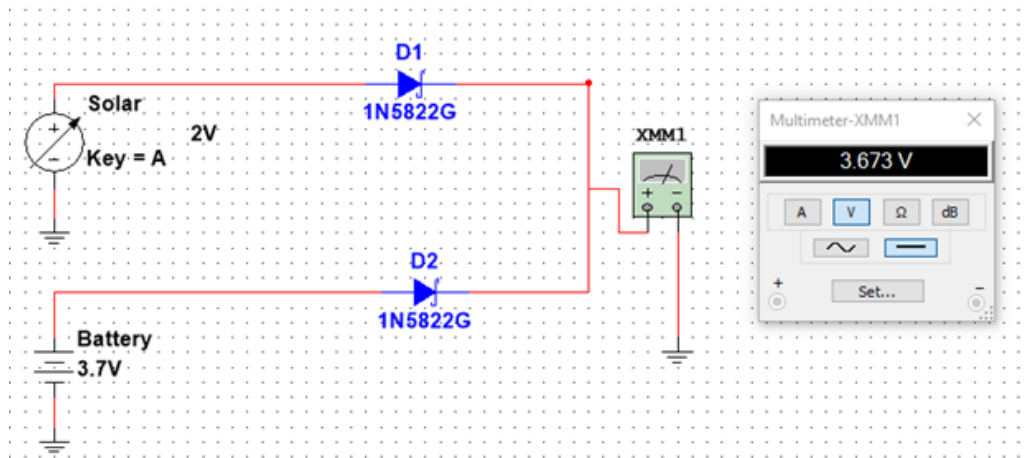

Figure 33: Battery voltage greater than solar cell voltage.

Another important aspect of the electrical design is heat dissipation due to power losses. Since the main housing is made of aluminum, it will act as a heat sink and all the excess heat will be dissipated into the pool water. The Raspberry Pi 3 B has a maximum current capacity of 2.5A, since the max load will not exceed 1A, a 2A fuse can be placed at the battery output as a safety precaution in case battery failure results in overcurrent. The

microcontroller will have four outputs and four inputs. The outputs will be the IR Camera, piezo buzzer, WiFi transmitter, and voltage source switch. The inputs will include the IR receiver via the PIR sensor, WiFi receiver, IR camera, and a thermocouple temperature sensor. As an added feature, the piezo buzzer can be driven by a low frequency oscillator to create a familiar alarm tone, after some testing, a 2 or 3 Hz sine wave will create the best result. Figure 34 shows the basic layout of the electrical system for the Baby Buoy.

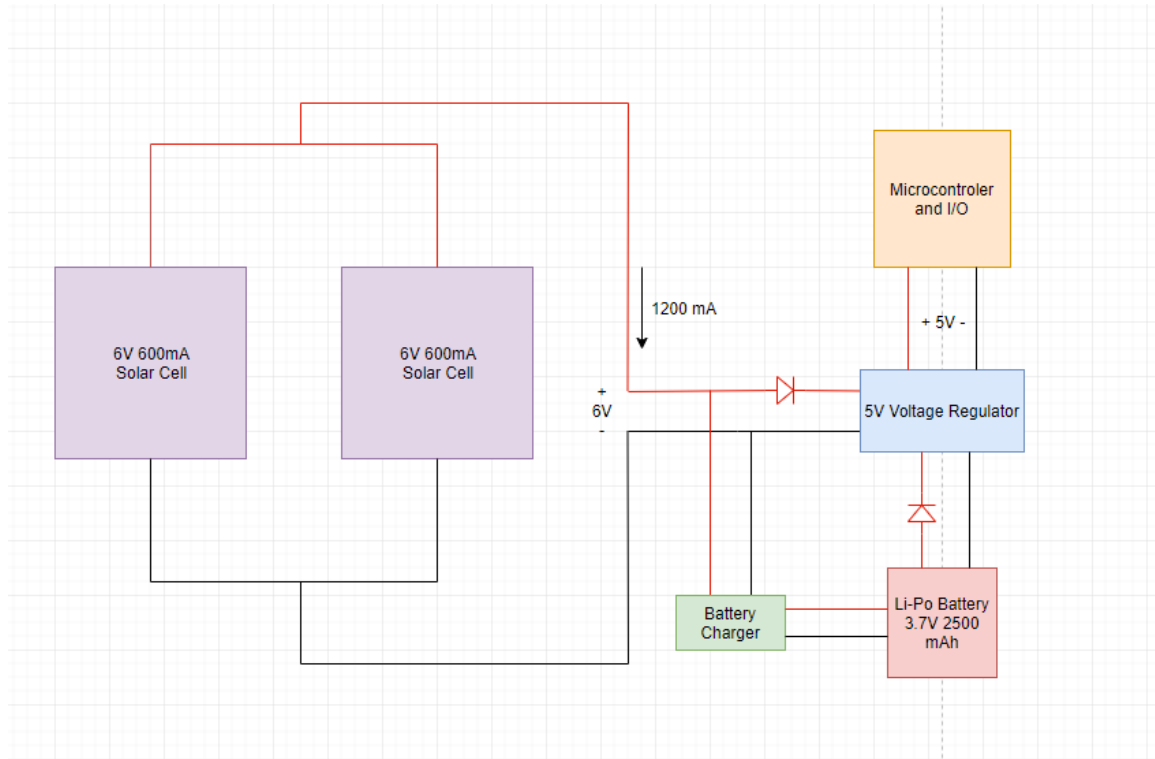

Figure 34: Electrical system layout.

5.3.1 Electrical Schematic

EasyEDA was used for the schematic design. All the IC components, including the BQ21040 battery charger, TPS6302 buck-boost voltage regulator, TMP36 temperature sensor, ATmega644 MCU, and PIR sensor HC-SR501 were found in the program's open source library. The piezo buzzer was added as a simple alarm output while the camera and WiFi modules were added as generic inputs. Once the schematic is complete, EasyEDA will also be used to convert the design to a PCB and manufacture it. EasyEDA markets their ability to produce and ship PCBs within a week of ordering. The figure below depicts the schematic design. The battery charger IC contains six pins, VOUT charges the battery at the programmed current, VIN is the power supply voltage, ISET is used to program the charging current by selecting an appropriate resistor, for this design, a 820Ω resistor was used to make the charging current 0.65A. GND pin is simply to connect the IC to the ground plane, CHG is an optional pin that is used to light an LED when the battery is charging as a form of feedback. Both VIN and VOUT have decoupling capacitors to reduce noise in and out of the IC, 1μF capacitors are recommended in the datasheet.

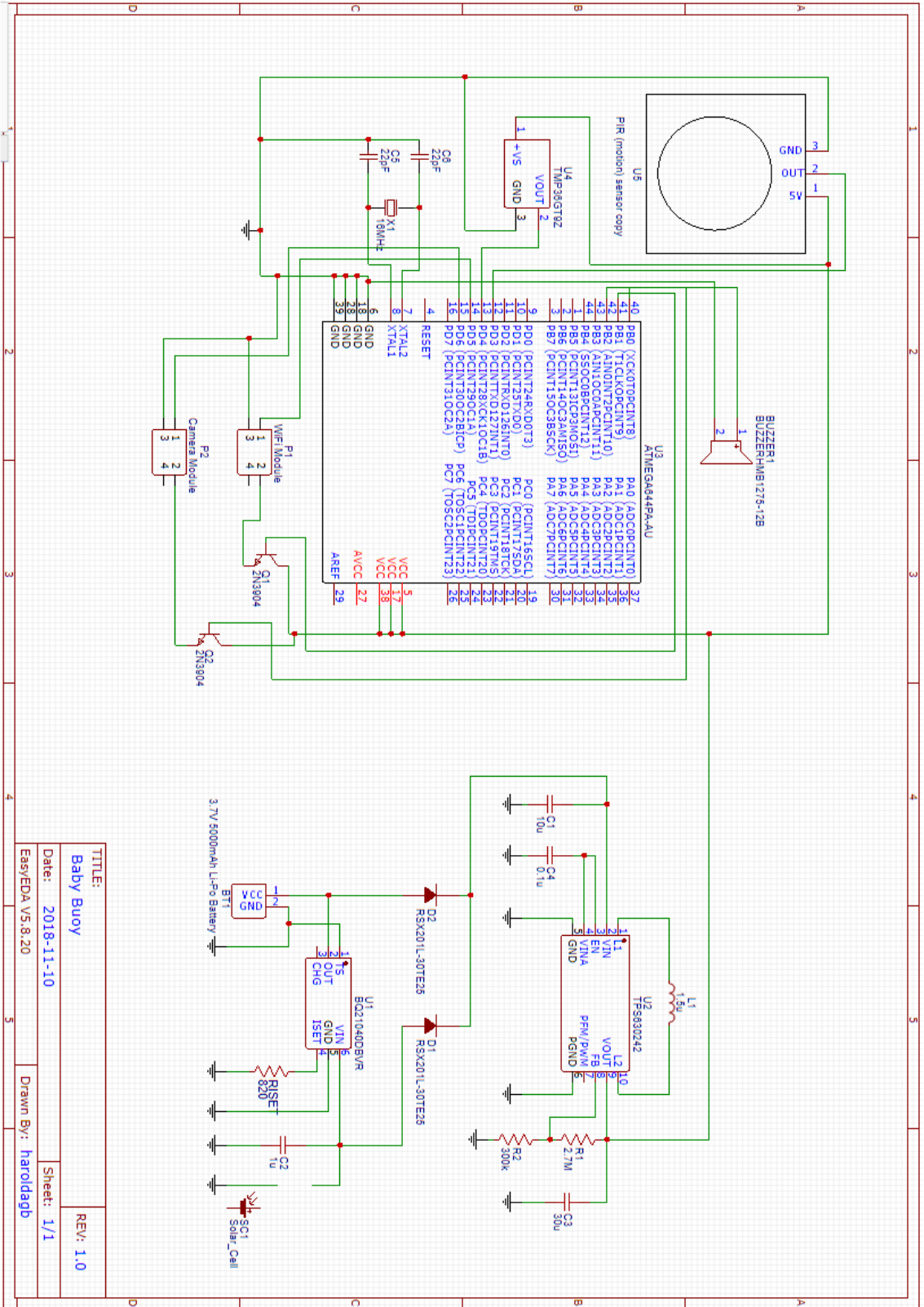

Figure 35: Schematic diagram

The voltage regulator IC contains fourteen pins plus the power ground which is an exposed thermal pad at the bottom of the component. EN is the enable input, FB is the voltage feedback for adjustable versions, GND is the basic grounding pin. L1 and L2 are connector pins for the inductor, the datasheet recommends a 1.5 μ H inductor. PG is the power output good, PS/SYNC enables and disables the power save mode, VIN has two pins to share the load coming from the power supply. VINA is the supply voltage for control stage. Finally, VOUT also has two pins to share the load of the regulated output voltage going into the circuit. VINA, EN, and PS/SYNC are not used in this design so they are grounded with a 0.1 μ F decoupling capacitor to disable them. Both the input and output voltages also use decoupling capacitors to lower the noise. The output voltage is programmed by the ratio of resistors R1 and R2, the values selected for an output voltage of 5V were R1 = 2.7M Ω and R2 = 300k Ω . R1 is connected to VOUT and FB while R2 connects to FB and ground, the resistors act as a voltage divider for FB.

The TMP36 temperature sensor operates between 2.7 and 5.5V input, it only has three pins. Pin 1 is the input voltage and pin 3 is ground. Pin 2 is the output voltage which changes depending on a range of temperatures from -40 $^{\circ}$ C to 125 $^{\circ}$ C. It is already calibrated to degrees Celsius for a set voltage change so there is no need to calibrate it. It is a single input device going into the MCU. The piezo buzzer simply connects to an output pin in the controller and the ground plane.

The AMG8833 camera also has its own PCB design with voltage regulator to step down the input voltage to 3.3V, it has four mounting holes and six pins. The pins include VIN which can take input voltages ranging from 3 to 5 volts DC. The 3Vo Pin is a 3.3V output voltage from the regulator, it provides up to 100mA to power other components. The GND pin is used to connect to ground, SCL is the I2C clock pin, it connects to the MCU I2C clock line. The SDA is the I2C data pin, it connects to the MCU I2C data line. INT is the interrupt output pin, it can be used to detect movement or other changes in the sensor's field of view. The AMG8833 also has another top row of through holes that look like more pin connections, but they are there for mechanical stability only, not for interconnections.

For wireless communication, Adafruit HUZZAH ESP8266 breakout board was selected. This board contains four power pins, two serial pins, nine GPIO pins, and one analog pin. The power pins include GND for grounding the board, V+ and Vbat which provide power to the built in high current voltage regulator. There's also a 3V pin that provides regulated voltage to be used for other devices. The two serial pins are TX and RX, they are most commonly used to communicate with the ESP module. TX is the output from the module, it is 3.3V logic, RX is the input into the module and it is 5V. TX and RX are repeated in two different sections of the board for design flexibility. The GPIO pins are named #0, #2, #4, #5, #12, #13, #14, #15, and #16. All of them are 3.3V logic level in and out, not compatible with 5V. Each pin can draw a maximum of 12mA. GPIO #0 is used to determine when to boot into the bootloader, holding the pin low when powering up will activate the bootloader. GPIO #2 also detects the booting mode, it is connected to a blue LED near the WiFi antenna. GPIO #4 is used for I2C SDA and #5 is used for SCL. GPIO #15 also detects the booting mode. GPIO #16 is connected to the RESET pin and is used to wake up from deep-sleep mode. The single analog pin is called A and has a maximum

voltage of 1V. The ESP8266 also has other control pins including LDO, which enables pins for the 3.3V voltage regulator, connecting this pin to ground turns off the regulator. RST is the reset pin, it is pulled high, pulling it down will reset the WiFi module. Finally, EN is the enable pin, when pulled down it also resets the ESP8266.

5.4 Software Design

The basic interface of the mobile application can be illustrated in Figure 33. The class diagram establishes the classes and operations in a basic structure, in efforts to illustrate the relationship amongst objects.

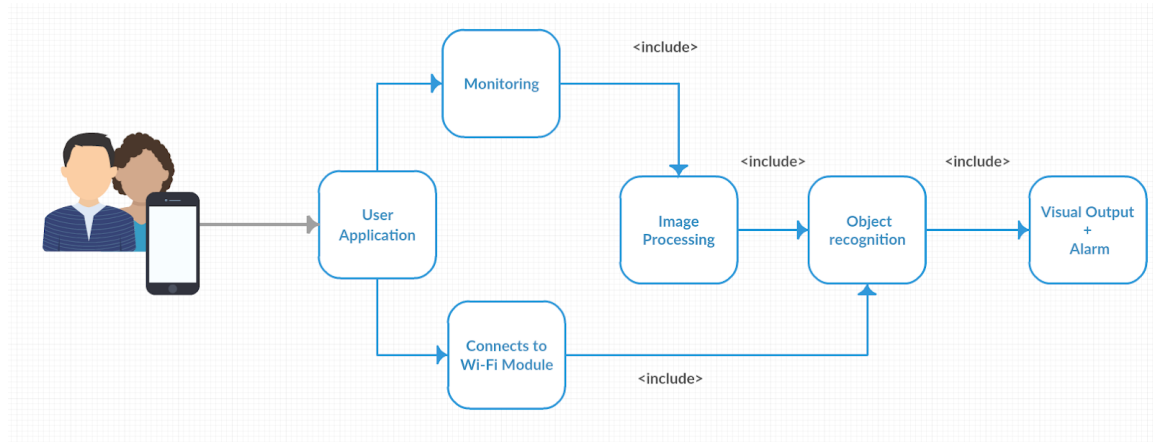

Figure 36: Basic Class Diagram of Software

Based on the illustration above, a user will have a friendly interface to operate and manage the device from the use of a mobile application. The application itself will have the abilities to manage the general setting for Wi-Fi connectivity that will lead it to having the capability of monitoring and view images from the onboard cameras of the Baby Buoy device. In the software that will be encrypted within the PCB board, image processing calculation will run through any video feed that is being received by the on-board cameras that are monitoring the surface of the water and underneath. From collecting analyzing the image and turning it into pure data, the computer vision, that will also be programmed into the PCB board, will draw up a decision on if the object that it is visualized in danger or if it is false accusation. After drawing up a conclusion, based on the conclusion, the on-board computer will decide if to stay dormant or to set the alarms and send out a notification to parent or emergency personal.

This is a very basic high-level class diagram, in the following sections we will go more in detail on what actual class and function will be store in each the class that will be created in efforts to master the mobile application and its software development.

5.4.1 Software Class Diagram

The image below illustrates the high-level design of the Baby Buoy mobile application. This class diagrams goes into a descriptive detail of the individual headers and probable

structures that would play a role within each class. This high level design will integrate an ease of functionality between the user and the device visuals.

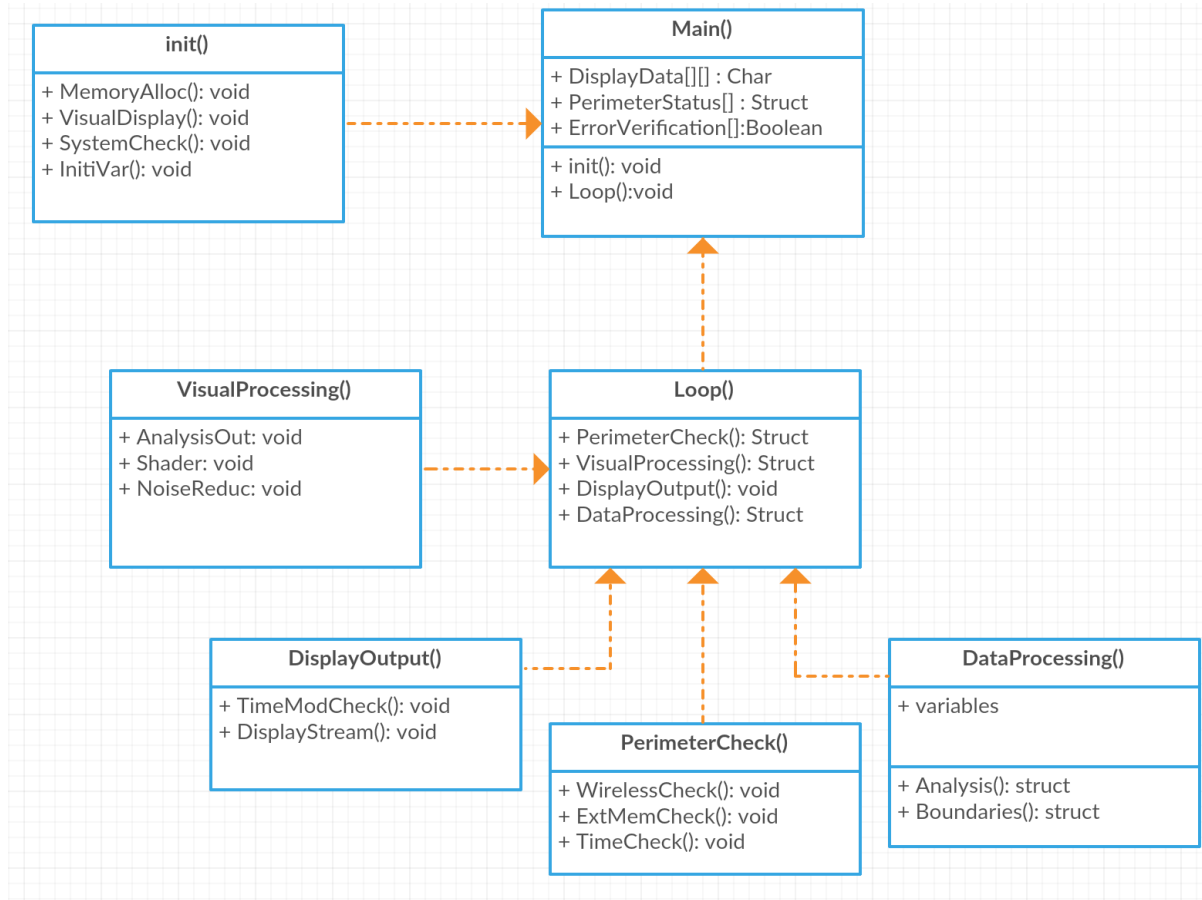

Figure 37: High-Level Class Diagram of Software

In the high-level class diagram that is illustrated above there will be a main class that will essentially be the image processing of the video feed that will be streaming in through the camera in the housing of the Baby Buoy device. This video streaming will always not be , in efforts to save power. Therefore, there will be a loop that will conduct a perimeter check every so often in attempt to save some battery life. This loop interview is a very small period that will not affect the actual functionality of the device. In this same perimeter check, the program will verify a strong wireless connection between the board and outside connected devices, allocate memory to store the video footage, and keep track of the time based on the on-board clock to give an accurate feed on the user’s interface.

The loop function is very important through the program iterations, as it also holds the display output feed, the object recognition algorithm and the some of the image processing requirements. In the visual processing function , there are shader and noise reduction that are going to be implemented to better depict the object that is in the water. Certain checks will be run through the the initial class that will verify the system is running at a good rate and that there is enough memory. This is a much higher-level design and one can visually

see what some of the elements are that will be tracked and checked while the cameras are monitoring the surface of the pool.

5.4.2 MCU Software Interaction

To obtain an accurate depiction of the video stream from our installed cameras, time and date will be put into consideration. This action will be done by the “on-board” module that contains this information. The base idea is to pull the video stream feed from the current time and date and send that to the Wi-Fi module on the microcontroller to have it be received on the user application.

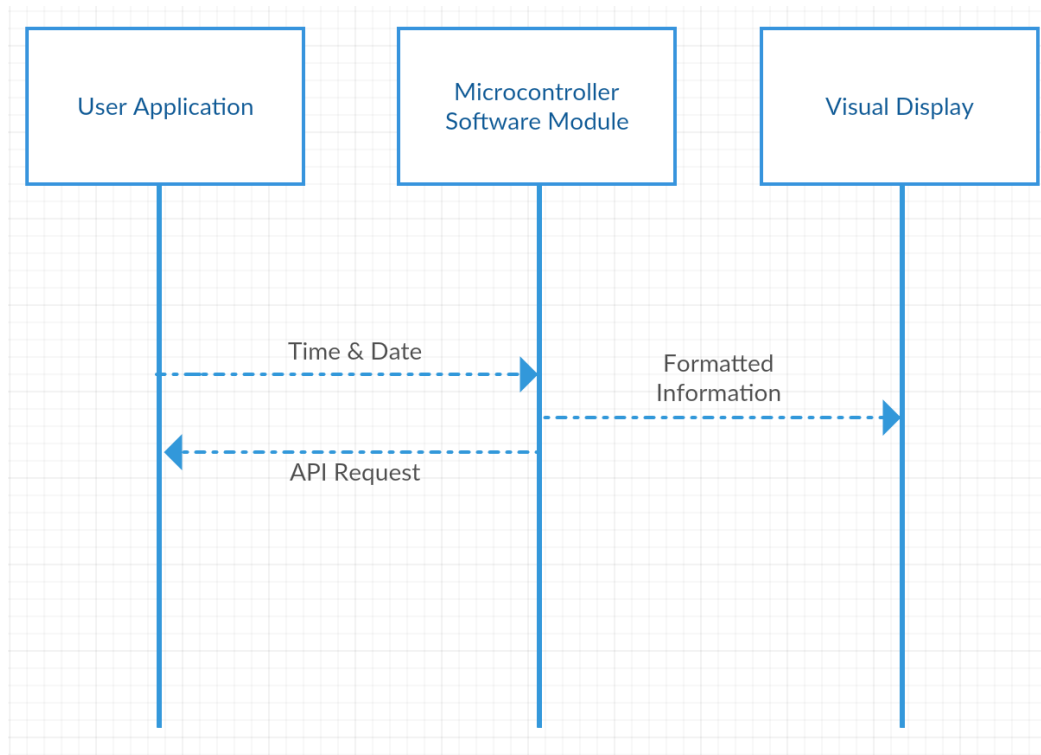

Figure 38: Microcontroller Software Diagram

Figure 38 illustrates the interaction that the all application have with each other. The user application on any mobile device will be retrieving the time and date from the on-board clock in the microcontroller. The microcontroller in return will interact with the mobile device through the application program interface (API). From the visual display, the microcontroller will be extracting the image data and converting it into data that can be interpreted by the Microcontroller and deciphered using computer vision.

5.4.2.1 PIR Sensor Communication

The microcontroller will communicate with the PIR sensor via a digital pin. The PIR sensor has 3 pins; VCC, OUT, and GND. VCC in this case is 5V, which can come from the voltage source, GND is connect to ground, and OUT is connected to a digital pin on the microcontroller. From the digital pin, the microcontroller will communicate with the PIR

sensor to send a HIGH signal or a LOW signal. A HIGH signal means that the PIR sensor has detected motion, more important an object or human that contains heat. After the high signal, the PIR sensor will remain HIGH until the object is gone. At this point, the PIR will set its output too LOW for about 3 seconds. For our project, the MCU will send a signal to the IR camera when a HIGH signal is triggered from the PIR sensor. With the HIGH signal, the IR camera will be activated to detect if an object or a human has fallen into the water. The PIR sensor is crucial in the 2-step verification method that the Baby Buoy system has. This will allow for reduced false alarms and low power consumption.

5.4.3 User Interface (UI)

The user interface of a mobile application is crucial to creating a mutual relationship between the device and the user. Having the ability to read any directional text and to see any pictorial images crisp and clear, gives the user a clarity of how to best maneuver throughout the app without assistance. The application for this project will be very user-friendly. With sharp images and visual text, so that the user does not place strain in their eyes. Figure 36 illustrates a very basic prototype of what the team would like to accomplish as the mobile application that would be tied together via Wi-Fi with the Baby Buoy device.

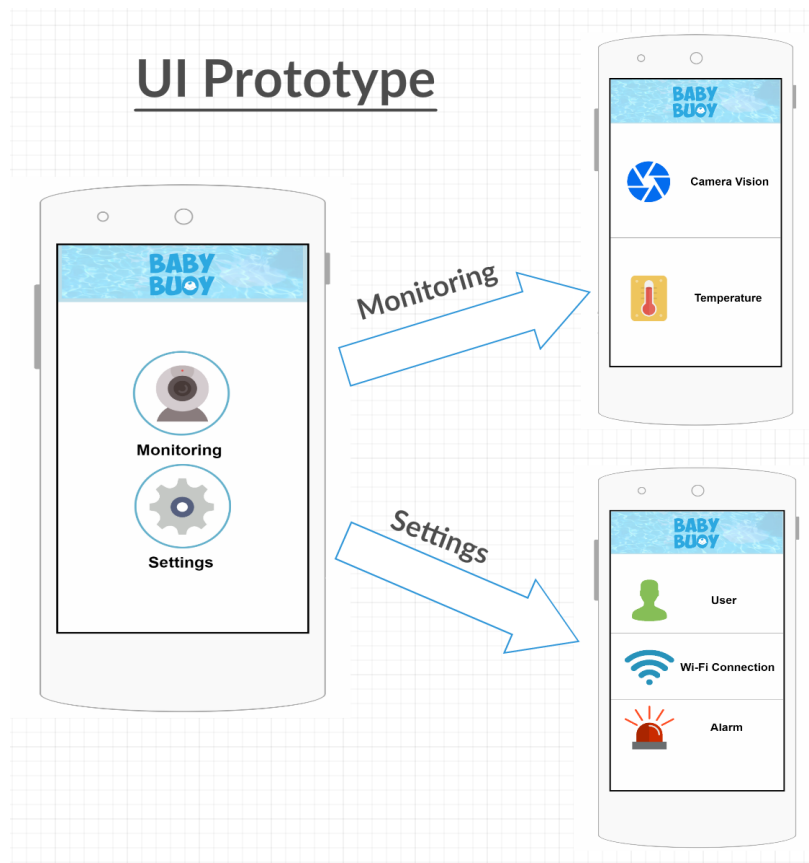

Figure 39: UI Prototype

Figure 39 illustrates the UI prototype that demonstrates some key features that the team would like to implement on the final product. At first glance, a user may notice prototype

is minimalistic. This will hold true for the final mobile application, as a minimalist design is seen to attract better user mobility as well as clarity. One may also observe that there will be images that tie together with the descriptive text so that both the visual learner and that reading learning may be satisfied. The following UI is illustrated on a 360 x 640 Android mobile device, this is a very common screen dimension for many phones such as the standard Pixel and Windows phone, which use the Android platform. A struggle the team will face developing in this platform will be, optimizing for different dimensions that do not fall in the standard (360 x 640). Figure 39, is solely a prototype where the icons, text, and colors are all subject to change when final development commences.

6.0 Project Testing and Prototype

The purpose of prototyping and testing is to construct a physical model of the Baby Buoy, as well as make sure that all components are running properly. In the following section, tests will be conducted on the hardware as well as the software portion of the project. An in-depth description of prototyping the PCB board will also be included in this section.

6.1 Testing

The following section will cover test procedure that will be conducted in order to ensure that all components within the Baby Buoy device work and operate together properly. Test expectations and potential issues will be discussed as well as test specifications.

6.1.1 Hardware Testing

In the Baby Buoy project there are several hardware components that will require specific consideration when it comes to the final device production. Although it is easy to assume that all parts that are new from factor “work”. It is safer to test the components beforehand on a breadboard or a test board, than to assume the parts work. Once all components are tested and show to be properly working, one may install them onto the PCB board.

Even during installation of components, one is running the risk of damaging the component while it is being installed. Therefore, it is also good practice to plug the final design into the main power, then use a multimeter to test the various nodes that are mentioned in the circuit diagram.

6.1.1.1 Wi-Fi module Testing

The ESP8266 can be easily programmed and tested using the Arduino IDE. The Wi-Fi requires only a micro USB cable to be paired with any PC that is capable of running the Arduino IDE.

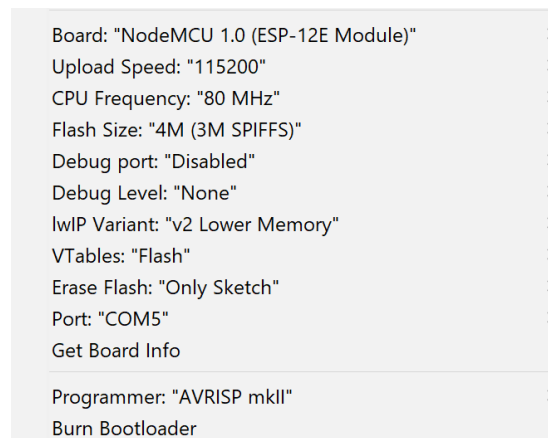
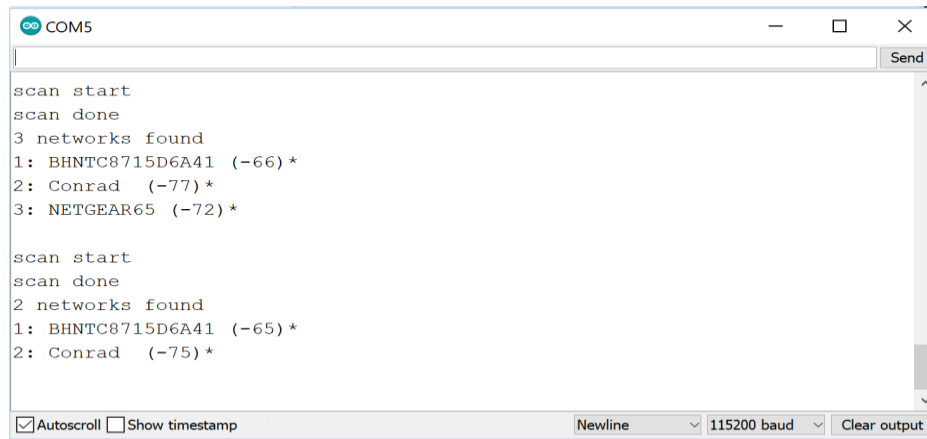

Figure 40: Wi-Fi Setup

Within the Arduino IDE, the ESP8266 must be installed into device manager manually. Once the device is installed you must setup the serial port to COM5. The baud rate to 115200 and the frequency to 80MHz. When all the setting to the serial port are configured a test program that can be found on the Arduino forms is uploaded onto the board. This process will take a minute. When the upload is complete the Wi-Fi module will begin scanning for networks around the area. If the module is not performing the scan, the PC might not be supplying the needed 3.3V for it to operate properly.



```
COM5
scan start
scan done
3 networks found
1: BHNTC8715D6A41 (-66)*
2: Conrad (-77)*
3: NETGEAR65 (-72)*

scan start
scan done
2 networks found
1: BHNTC8715D6A41 (-65)*
2: Conrad (-75)*
```

Figure 41: Wi-Fi Testing

6.1.1.2 AMG8866 Camera Testing

The AMG8866 Camera can be easily tested using an Arduino UNO board. Before wiring the AMG886 on a breadboard and Arduino UNO, the tester must download the Adafruit library that can be found on their website. Once the library is downloaded onto the PC, the Arduino IDE will be able to find the library and install it through the Library Manager. Within the library, Adafruit has compiled two tests to ensure that the AMG8866 is working properly. One test is for the thermistor. When you upload the thermistor program onto the Arduino UNO and have COM3 reading at 9600 baud speed, the serial port should be outputting approximately 26 degrees when everything is working correctly.

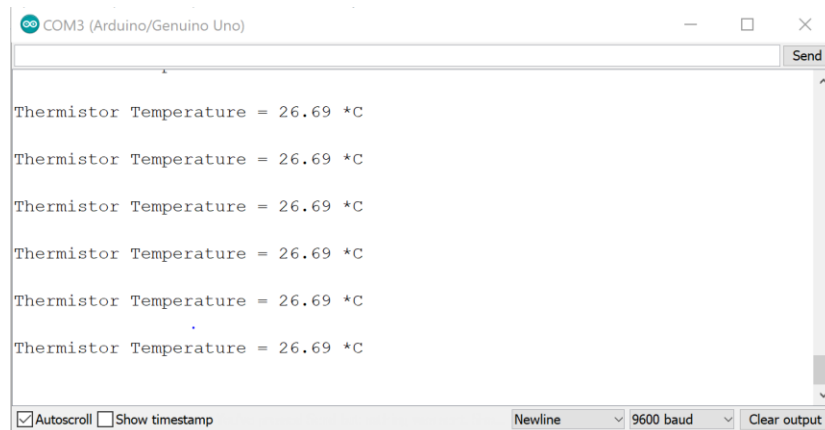

```
COM3 (Arduino/Genuino Uno)
Thermistor Temperature = 26.69 *C
Thermistor Temperature = 26.69 *C
Thermistor Temperature = 26.69 *C
Thermistor Temperature = 26.69 *C
Thermistor Temperature = 26.69 *C
Thermistor Temperature = 26.69 *C
```

Figure 42: Thermistor Test

The second test is a pixel array. Some procedures, such as the thermistor test, Adafruit provides special libraries that can be found on their website. One of these libraries are for the AMG8866, which once downloaded, is compatible with the Arduino IDE. Once you upload the program through COM3 reading at 9600 baud speed an array of numbers will output in the serial port. Each number that is outputted is the celsius of the detected temperature from the camera. The number should increase as the tester waves their hand in front of the camera and it will decrease when there is nothing in its scope of vision. The figure below indicates the user waving their hands and having the camera detect the heat from it.

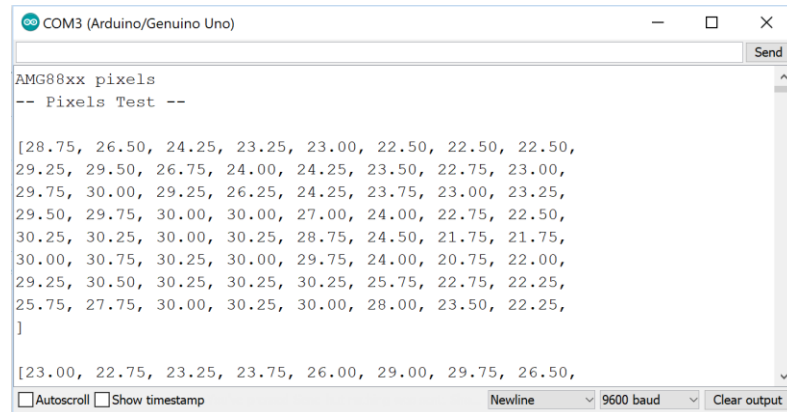

```
COM3 (Arduino/Genuino Uno)
AMG88xx pixels
-- Pixels Test --

[28.75, 26.50, 24.25, 23.25, 23.00, 22.50, 22.50, 22.50,
29.25, 29.50, 26.75, 24.00, 24.25, 23.50, 22.75, 23.00,
29.75, 30.00, 29.25, 26.25, 24.25, 23.75, 23.00, 23.25,
29.50, 29.75, 30.00, 30.00, 27.00, 24.00, 22.75, 22.50,
30.25, 30.25, 30.00, 30.25, 28.75, 24.50, 21.75, 21.75,
30.00, 30.75, 30.25, 30.00, 29.75, 24.00, 20.75, 22.00,
29.25, 30.50, 30.25, 30.25, 30.25, 25.75, 22.75, 22.25,
25.75, 27.75, 30.00, 30.25, 30.00, 28.00, 23.50, 22.25,
]

[23.00, 22.75, 23.25, 23.75, 26.00, 29.00, 29.75, 26.50,
```

Figure 43: Pixel Test

6.1.1.3 Solar Cell Testing

The two solar cells used for this project were rated for 6 volts and 600 mA, or 3.6 W. Since the cells were arranged in parallel, the maximum expected current is 1.2 A. To test this, the solar cell housing was placed outside under direct sunlight and the output voltage and current were measured using a multimeter. Measurements were done every 30 minutes from 8:00 AM to 5:00 PM. The solar cells were tested in two configurations, laying on the floor assuming normal operation and positioned directly facing the sun to get a maximum reading. The following Figures show the testing setup and results.

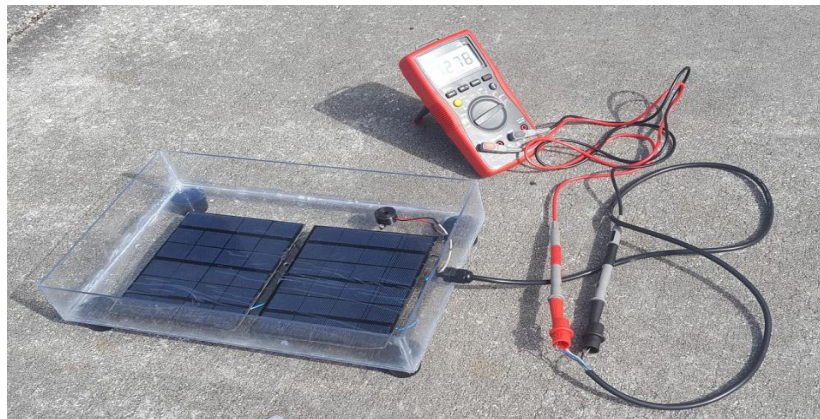

Figure 44: Solar Cell Test with multimeter

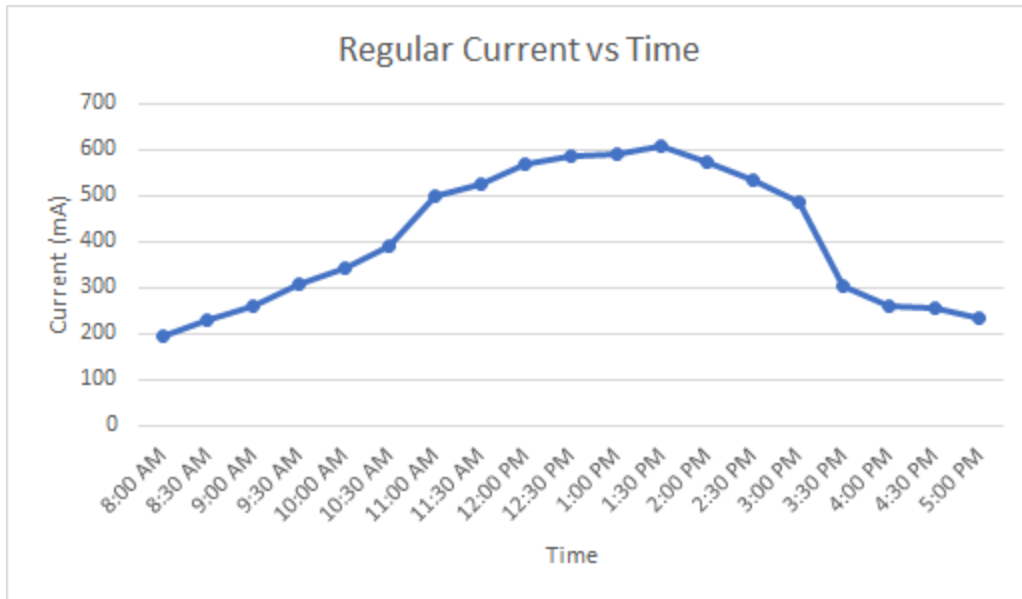

Figure 45: Solar Cell Test regular setup

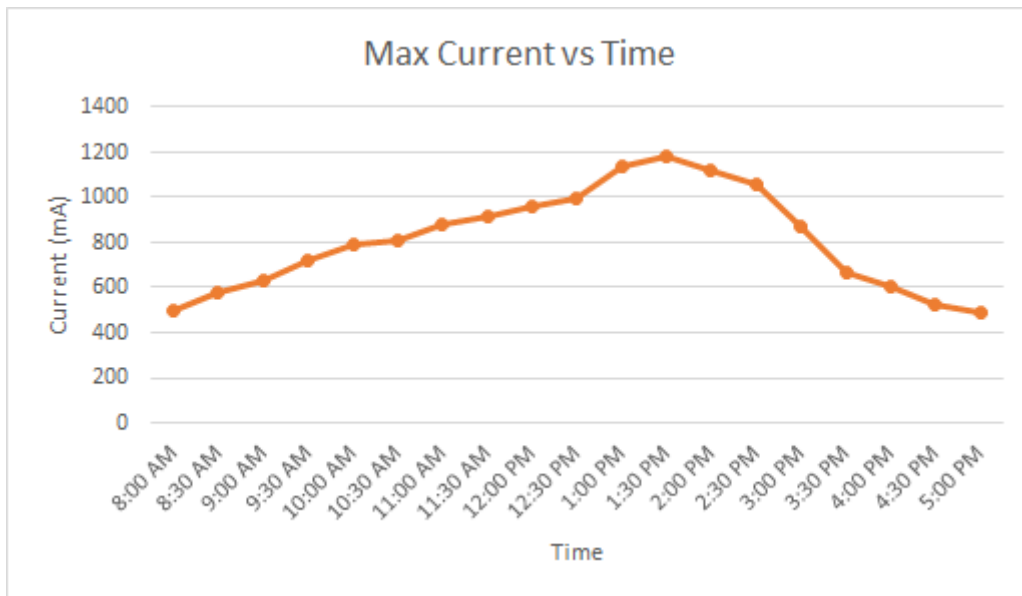

Figure 46: Solar Cell Test aiming cells at the sun

As seen in the figures, the current supplied by the solar cells fluctuated greatly depending on the position of the sun, the greatest current output occurred in the middle of the day, between 12:00 and 2:00PM. Furthermore, aiming the solar cells at the sun increased their output by roughly double, with the maximum measurement reaching the theoretical 1.2 A ideal output. The voltage was also measured throughout the day, with no load, it remained within 6.5 V to 7.1 V, the voltage remained constant when compared to the current measurements. The change in current was also drastic when a cloud or any type of shadow covered the cells, the output would drop by roughly 75% when the sun was blocked. Also,

the solar cell housing was tested without the top cover which is made of the same polycarbonate as the rest of it, although the cover is clear, a 20 mA drop in output current was noted when it was put on. The fact that the output current varies so much has made us reconsider using it as a power supply for the Baby Buoy, since the cells also need to provide enough current to charge the battery. The alternative would be to have the solar cells only charge the battery and the battery will be the sole power supply for the system.

6.1.1.4 Battery Charger Testing

The battery charger IC chosen for this project was Texas Instrument's BQ21040 surface mounted charger. The component was too small to test on the breadboard, besides the fact that it is SMD and not a DIP components, therefore small wires had to be soldered to each pin for testing. The charging current was set to 650 mA by placing a 820 Ω resistor in pin #4, this may change to a 675 Ω resistor for 800 mA charging if the solar cells are dedicated to charging the battery.

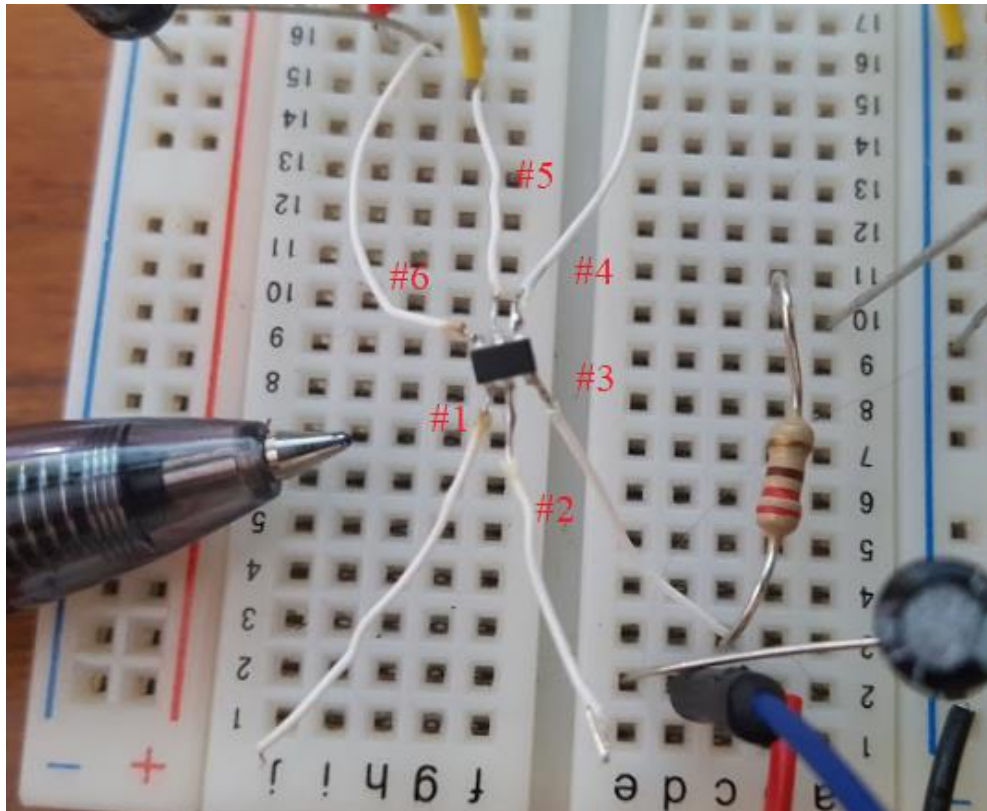

Figure 47: Battery Charger Wiring

The charger circuit was powered by the solar cells around 4:00 PM, charging the battery at around 200 mA. The current was tested by connecting one lead of the multimeter to the output pin #2 and the other lead to the node for the battery's positive electrode, making a series connection to measure current. The charging voltage was also measured, it was 4.1 V which is indicative of the second phase of lithium ion charging where the voltage is kept constant at 4.2 V while the current drops near 0.1C. The battery was already partially

charged, this is why charging started at the second phase. The voltage of the solar panels with a load was measured to be 4.4 V, well within the operational specifications of the charger IC. An LED was placed in pin #3 to indicate charging was taking place. However, the LED did not turn on, indicating that maybe the IC determined the battery was fully charged, or the LED was malfunctioning.

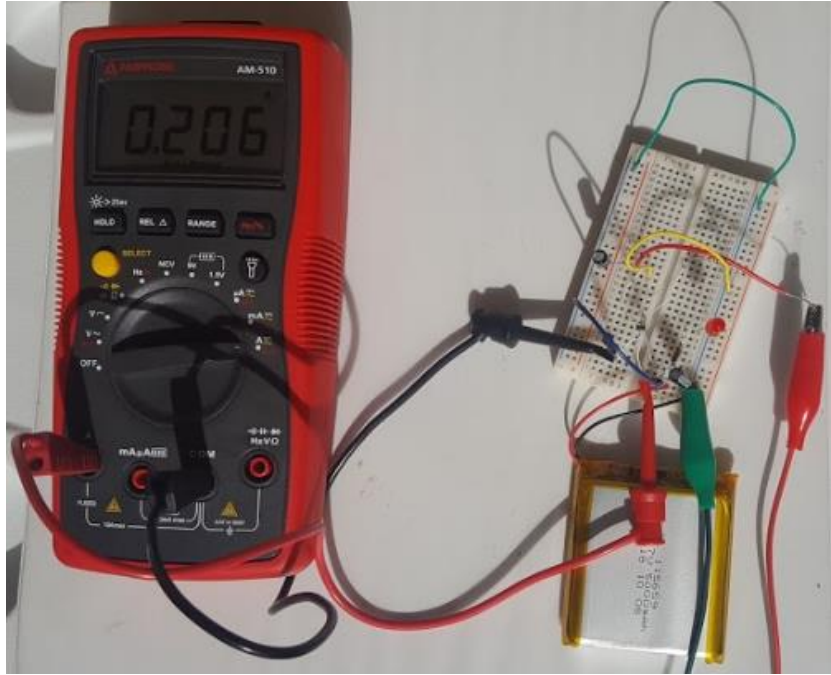

Figure 48: Battery charger output current

6.1.1.5 Voltage Regulator Testing

The voltage regulator chosen for this project was the buck and boost switching regulator TPS63020. This is another surface mounted component. However, the size makes it too difficult to solder by hand to test on the breadboard in the same way as the battery charger. This component has 14 pins in a similarly sized package as the BQ21040, making it impossible to hand solder. A way to test this component before integrating it into the final PCB design is to make a simple adapter PCB such as the one shown below.

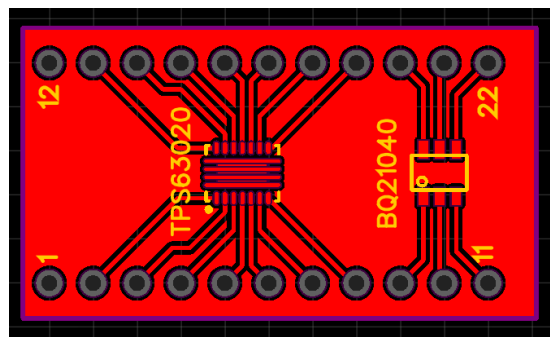

Figure 49: Battery charger output current

The plated through holes are spaced at 2.54 mm to fit the standard breadboard spacing for connections. Pins can be soldered to these holes and the board can be connected to any standard breadboard for testing the components. The manufacturing process for these boards takes a few weeks so the test PCB will not be ready in time for this semester.

6.1.1.6 Temperature Sensor Testing

The temperature sensor chosen for the Baby Buoy is the TMP36GT9. This sensor takes in 5V and outputs a voltage that is proportional to the temperature around it. This component was tested by plugging it to a DC power supply at 5V and measuring the output pin with a multimeter. The output voltage was then compared to the chart given in the TM36 datasheet Figure 6. The measured voltage was 0.710 V which, according to the plot, coincides with a temperature of 21 °C or about 70 °F. Since the thermostat reading at the time of testing was 72 °F, it can be said the sensor is fairly accurate, especially since the room where the sensor was tested was colder than the rest of the house. The temperature is calculated by starting with an offset of 500 mV for 0 °C and then scaling at 10 mV/ °C.



Figure 50: Testing temperature sensor

6.1.1.7 PIR Sensor Testing

The PIR sensor chosen for the Baby Buoy system is the HC-SR501. The sensor has pinouts for power, ground, and output from the microcontroller. The sensor was tested by powering it up with 5V, connecting it to ground, and having it output with a pin on the microcontroller. The sensor can be adjusted to detect motion from 3 meters to 7 meters. If motion is detected, the time delay can be from 5 seconds to 5 minutes. It also has 2 different types of triggers. Single trigger allows the time delay to begin immediately after motion is detected. Repeatable trigger allows the time delay to be resettled after each motion detection (time delay begins with last motion detected). The figure below shows the PIR sensor being tested with a separate LED for easy visibility. The LED will be ON when motion is detected and OFF when there is no detected motion.

The figure below shows that the PIR sensor is detecting motion and the length of time that motion was detected for. The initial line indicates that the sensor is calibrating and warming up. It needs at least 30 seconds of initialization before it can start detecting motion. After it is done calibrating, the sensor will be activated and ready to detect

motion. “Motion detected” is the start of when motion was detected and “motion ended” is when the motion was no longer detected.

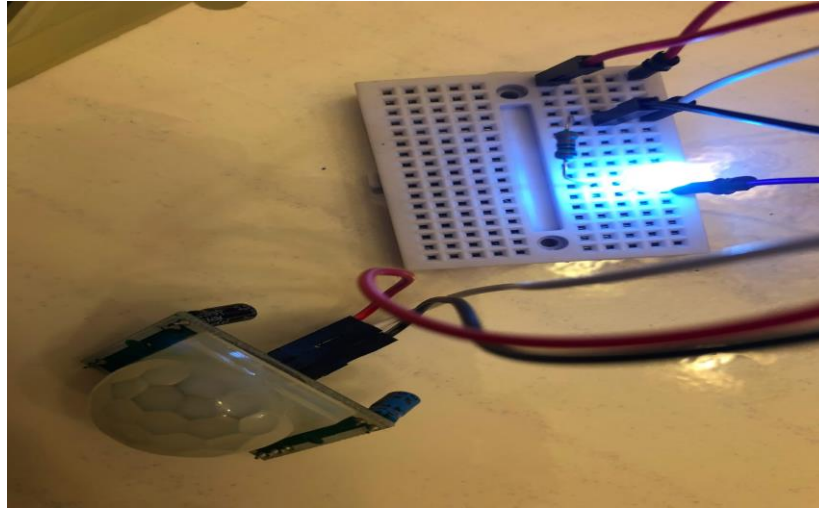

Figure 51: Testing PIR sensor

```
calibrating sensor ..... done
SENSOR ACTIVE
---
motion detected at 52 sec
motion ended at 60 sec
---
motion detected at 69 sec
motion ended at 74 sec
---
motion detected at 88 sec
motion ended at 91 sec
---
motion detected at 103 sec
motion ended at 106 sec
---
motion detected at 114 sec
motion ended at 118 sec
---
motion detected at 124 sec
motion ended at 135 sec
---
motion detected at 142 sec
motion ended at 152 sec
```

Figure 52 PIR Sensor Readings

6.1.1.8 Piezo Buzzer Testing

The Piezo buzzer is being tested by inputting a different voltage. The buzzer can operate with 4V to 28V. The higher the input voltage, the louder the buzzer is. The lower the input voltage, the quieter the buzzer is. The Baby Buoy system will run on 5V, therefore the piezo buzzer will have an input voltage of 5V for the project. The figure below shows the buzzer connected to a power source where it functions as it should.

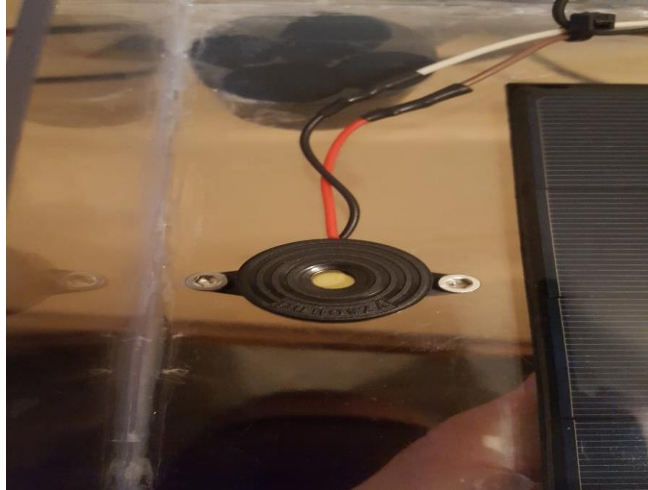

Figure 53: Testing Piezo Buzzer

6.1.1.9 Microcontroller Unit Testing

The microcontroller unit chosen for the Baby Buoy system is the ATmega644P. This microcontroller has twice the RAM and memory as the ATmega328P microchip. Programming the microchip is considerably more difficult than programming the ATmega328P microchip since it has its own development boards. In order to test the microchip, we used the Arduino Uno as the ISP (In-System Programmer). The ISP allows the microchip to be programmed while installed in a complete system, as opposed to programming the microchip independent of the system. The appropriate pins from the Arduino Uno board were connected to the appropriate pins on the breadboard where the ATmega644P microchip was connected. The LED on the breadboard indicates that it is powered on. The figure below shows the microchip being programmed and powered on by the Arduino Uno.

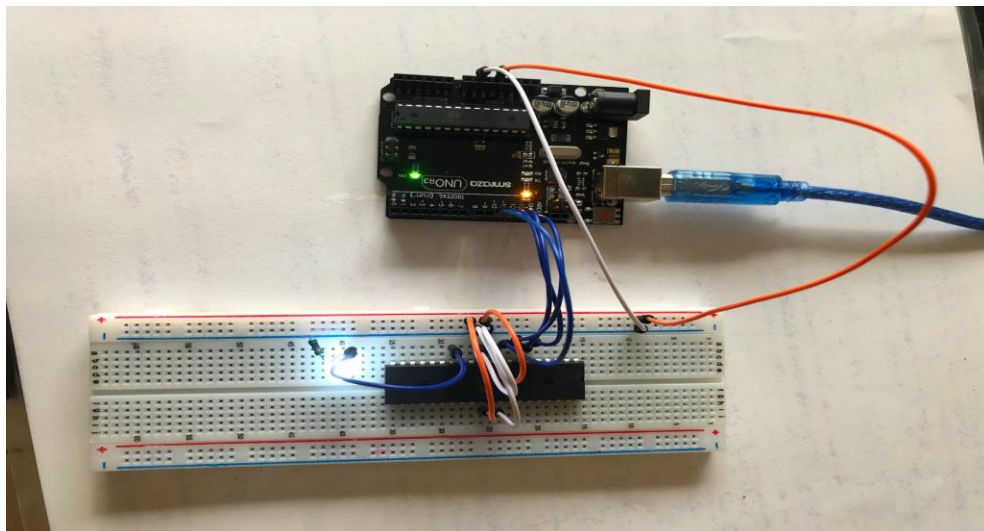

Figure 54: Testing MCU

The following figures shows the ATmega644P microchip being powered on by a power supply module with 5V input to the microchip. A blinking LED program was uploaded to the microchip for this example. The LEDs blink on and off for 1 second each. The left side of the table shows the LED in its OFF state while the right side of the table shows the LED in its ON state. The red LED on the power supply modules shows that it is powered on and supplying 5V to the microchip.

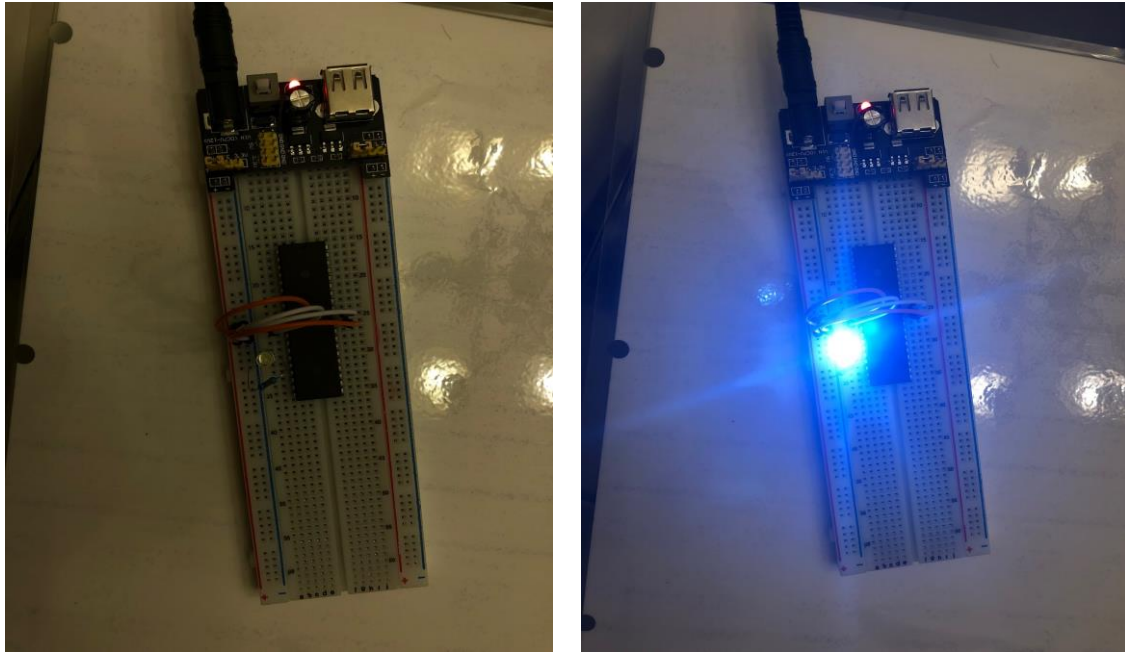

Figure 55: MCU LED Test

6.1.2 Software Testing

The software being implemented in the Baby Buoy project will be tested in order to verify that components operate as expected and will continue to operate as expected even after making modifications. This test will be conducted on a computer before being transferred to the actual microcontroller.

Unlike hardware, software is very easy to test and manipulate without the need of the actual components. With that being said; software testing will be performed throughout all the stages of development. Therefore, to limit the amount of potential problems.

6.1.2.1 Simulated Testing

Based on the microcontroller that has been chosen, the programming will be written in C. The Arduino microcontroller can accept languages C/C++. Out of experience the team feels more comfortable writing the internal program in C. Through the software development, various unit tests will be performed to push the boundaries of the program and ensure that everything operates correctly.

Unit tests are extremely helpful in software development. They are usually written before any lines of code are compiled. Their purpose is to make the developer think through the computer's logic and determine what needs a unit test and what to test for, which is a very important task. In the long run, performing this brainstorming exercise will prevent more work in the long run. Many large companies such as Microsoft used to have specialized developers that would only test and write unit tests. Unit tests are also very useful in tracing the amount of consumed memory within the MCU. This is very important as the team understands that the Baby Buoy project will be allocating a large amount of space in order to operate properly. By performing unit tests we can verify how much memory is being allocated and archived while the program is still being edited on the CPU.

The great thing about software testing is that you do not need the physical devices to perform a test. Software IDEs are developed to be able to compile and run tests on the CPU without the need to upload onto the physical board. Therefore, software testing is very convenient and can be done anywhere you have a working computer. The tested code will be performing tests on verifying inputs, checking for system overrides, and if the display is being updated. All of these are unit tests that are performed to construct a test-driven development. This test-driven development is to construct core modules that will allow a smoother user interaction.

Some examples of unit tests that the Baby Buoy team will be performing is in the motion detection above the surface of the water as well as object recognition underneath the water. These tests will be performed on a computer as well as through user interface, throughout each iteration to eliminate any possible errors.

6.1.2.2 Physical Testing

The physical test for the Baby Buoy project will be much harder to troubleshoot, to determine if a module is not working properly. The device will have a PIR sensor, IR camera, Wi-Fi module, and a buzzer. All of this will need to be tested physically in order to classify our device as functional. For the PIR and the IR camera will not be testable until the Wi-Fi module is sending and receiving information properly. This is because the user will be able to monitor these modules through a mobile application. Verification of a successful Wi-Fi connection is very important for the physical test.

In order to test that the Wi-Fi is working as intended the tester will need to verify the following procedure. To start turn on the Baby Buoy device and verify to the Wi-Fi is turned on. Once the Wi-Fi is turned on, connect it to your nearest router for internet connection. The user should then access their mobile device and switch the Wi-Fi settings to be connected onto the Baby Buoy device. If the Baby Buoy device is not chosen present, this is an error. To best troubleshoot this issue, first verify that the device was successfully connected to the Wi-Fi router, then follow this step by checking the IP address that it is synced to. Once both tests have been performed. The issue is in the program and the tester must go back into the computer and verify their variables.

If the mobile device was able to connect properly, the tester may move on forward and open up the user application. The user application must be tested separately to make sure

it is user friendly and easy to navigate. Within the user application all button must lead to another page or turn ON/OFF something. The user must be able to access and alter their account information under a settings tab. All transition from various screens must be smooth and efficient with zero lag or wait time.

Within the mobile application the user will be able to monitor the PIR sensor as well as the IR camera. This will be tested individually. PIR camera will be tested by exhibiting motion in front of the sensor and see if the mobile application will send out a notification. If no notification was sent the tester can go into the logs with the application and check that there is an entry for the motion. If no entry was made information was never sent out from the device, therefore the PIR sensor is not communication to the MCU. This can be due to motion sensitivity settings within the program or the PIR sensor not being properly installed in the PCB board. In worst case scenario the sensor was damaged in the midst if installment and is now broken.

For in order to verify the IR camera the PIR sensor must capture movement. Once the PIR captures movement the IR camera will turn on as a second step verification. Once the device picks up motion it will send the user a notification and turn on the underwater IR camera. The visuals will be accessible from the mobile application on a specific tab/button. If there is no visual feed being observed from the user application, the user will have to check in with the logs. If there is a no log being created for the IR camera turning on, then there is an issue in the code. If there is a log being created the the issue is hardware. This can be created from improper wiring, wrong installment on the PCB board or in worst case scenario the device was damaged in the installation process.

Once the IR camera is communicating once the PIR sensor in trigger the last user test is the buzzer. The test the buzzer teh tester must simulate a fake fall into the pool and have the IR camera identify it as a human. This action will activate the buzzer and mobile device sending out a distress signal. If the buzzer is not activated teh IR camera failed to identify the image captured as a human, therefore the issue would be caused from the computer vision programming. If in the logs, the IR camera does output “DANGER” the buzzer might be incorrectly installed, or it might have been damaged while it was being installed onto the PCB board.

Given that all test is proven to be valid the device will be classified as operational. Due to the long strenuous effort that must be put into the device for it be to be physically tested properly, most of the testing will be done under computer simulations. The following steps for testing will be performed to in order to verify successful integration and hardware specific code. With proper testing, the Baby Buoy device will exhibit proper device operations and a hassle-free user interface.

6.2 Prototyping

The main design for the Baby Buoy project have been discussed in previous chapters. Now the team will be evaluating the boundaries of the physical circuit board. All major components to the Baby Buoy project have been purchased and are undergoing testing. In

the following section there will be discussion on what are the expectation of the microcontroller as well as potential hardware and software issues.

6.2.1 Potential Hardware Issues

Some of the most common hardware issues that may be experienced throughout the course of this project are time delays and nonoperational parts. Time delays may be caused from not having the appropriate parts at a given time. For example, not having the connecting cables needed to send power to the Wi-Fi module. This would result in a time delay as the team will not be able to test out the feature till the cable arrives. The delay in turn will cause further delays of other components down the road being that the Wi-Fi module will be communicating with various other components.

Although nonoperational parts are less common when they are being shipped straight from the factory, it is still a possibility. This issue may be easily solved from ordering multiple units and testing each individual unit. By ordering multiple units, the team will be reducing the risk of acquiring a damaged or faulty unit from the beginning. Furthermore, each individual unit will be testing outside of installation on a breadboard or other device to ensure that is operating properly.

Some other hardware issues that the team might face is in soldering the parts onto the PCB board. This must be done with care and precision. The functionality of the device depends on the success of the properly soldered parts. This is a nervous topic for the team, as no one has performed soldering before. Thus, the team is practicing beforehand on test soldering kits to insure that once the PCB board is received the team is able to solder the pieces properly.

Throughout the gathering of the parts and testing them the team is taking their time in order to ensure that all the ordered part is functioning properly. This will insure that the part are operational and that there will be no need to make multiple orders, that cause a time delay. The Baby Buoy team is aware of their abilities and are taking precautionary test when it comes to the lack of soldering knowledge by doing individual practice of soldering kits.

6.2.2 Potential Software Issues

Some of the most serious software issues are caused by a hardware failure. These errors can range from frequent crashes with various errors each time or having the system run extremely slow which would indicate either an issue with the memory (RAM), hard disk, motherboard or even overheating problems.

Some ways to insure these issues do not hinder the functionality of the device is being addressing any errors individually. When programming the IDE will be able to compile your code to test if it has any logic issues. If there appears to be logic issues, they will be addressed in the terminal so that the user can target them individually. The possibility of memory issues is also very likely, being that software will be receiving large sized files from the IR camera to determine if there is an object in the pool. Therefore, memory is very important to allocate when programming. It is also important that it is properly cleared

by archiving the memory once it is used. To user that there is enough memory while running the program, before it is uploaded onto the device, unit tests will be performed. Unit testing has been covered in a previous section 6.1.2.1 Simulation Testing.

Multiple simulations on the IDE, running a various set of unit test will be performed to ensure that the amount of software issues is reduced or eliminated completely. The software is as important as the hardware in the Baby Buoy project. They are both tied together, and both will be handled with time and care to insure a proper delivery on the due date.

7.0 Administrative Content

In the following section information pertaining the division of labor, project milestones, and overall cost of the project, are documented with descriptions. All group members are responsible on carrying an administrative role throughout the timeline of the project. All information is subject to change under certain circumstances that would prevent the completion of milestones throughout the two-semester period. Engineering and design require a large amount of effort, thus administrative planning is crucial for the success of the team.

7.1 Project Budget/financing

Table 7 shows a preliminary budget for major components of one unit. The list is not a comprehensive itemized list. This list is missing small miscellaneous components, testing equipment, and tools. As overall for our budget we are pushing to stay under \$300. To make the device marketable and competitive we will be aiming to lower the cost subtotal. We are currently self-funding the project. We do intend on reaching out for funding to ease our capital strain.

Table 7: Project Budget

Part	Quantity	Price
PIR Sensor	1	\$10
Camera module	1	\$40
Wifi module	1	\$10
Alarm module	1	\$5
PCB	1	\$60
Rechargeable Battery	1	\$20
Waterproof Housing	1	\$80
Articulating Arm	1	\$20
Solar Panel	2	\$30
Single Unit Subtotal:		\$275

Table 8 shows the actual amount of money the team has currently spent on developing the Baby Buoy system. Other items may be added as project items may be needed. Currently, the project seems to be under budget with most of the expensive components.

Table 8: Project expenditures

Part	Quantity	Actual Price
PIR Sensor	1	\$1.72
Camera Module	1	\$40.00
Wifi Module	1	\$10.00
Alarm Module	1	\$1.96
ATmega644PA-PU	1	\$5.25
16 MHz Crystal	1	\$1.38
22 pF Capacitor	2	\$0.75
PCB	1	\$2.00
BQ21040	1	\$1.26
TPS6302	1	\$2.85
TMP36GT9	1	\$1.54
Rechargeable Battery	1	\$15.99
Main Housing	1	\$80.00
Solar Cell Housing	1	\$21.98
Articulating Arm	1	\$14.98
Solar Panel	2	\$21.00
Single Unit Subtotal:		\$222.66

7.2 Initial Project Milestones

This section shows the milestones from the beginning of Senior Design 1 to the end of Senior Design 2. These milestones were decided upon as a team in the initial Senior Design

Bootcamp and are subject to change as the class progresses and project needs change. The table below shows the teams project milestones with the expected dates of completion.

Table 9: Project Milestones

Senior Design I	
Milestone	Date
Project Idea Assignment	Aug. 24, 2018
Boot Camp	Aug.29, 2018
Divide and Conquer Document	Sept.14, 2018
Half Hour Meeting	Sept. 22, 2018
Update Divide and Conquer Doc	Sept. 28, 2018
60 pg Draft Due	Nov. 2, 2018
60 pg Feedback	Nov. 5-6, 2018
100 pg Draft Due	Nov. 16, 2018
Final Documentation	Dec. 3, 2018
Senior Design II	
Milestone	Date
Build a Prototype	Jan 7-Feb. 7, 2019
Test and Redesign	Feb 9-22, 2019
Finalize Prototype	Feb 25-March 7, 2019
Peer Presentation	TBA
Final Report	TBA
Final Presentation	TBA

8.0 Conclusion

After testing all the physical components and yielding positive results, it is expected that the Baby Buoy device will perform as necessary. The solar cell array behaved as expected, with a maximum output current near 1.2 A. Although the drastic drop in current when shadows covered the cells was more than expected. The rise and decline of output current throughout the day was also expected. The Li-Po battery charger worked correctly, providing constant voltage to an almost full battery with a current well below 10% of the capacity. These parameters indicate that charging was done properly. The temperature sensor also worked as indicated by the datasheet, the output voltage was converted to the correct room temperature at the time of testing. Although it was not possible to test the switching voltage regulator, a plan was formulated to do so before the PCB is ordered.

The ESP8266 Wi-Fi module was successfully detected by the computer and functioning as it should. It was able to clearly detect wireless networks around the area without any complications. The thermistor on the AMG8866 camera also worked as it should, where the 26°C output on the computer screen shows a successful program test. The second test for the AMG8866 camera is where a pixel array is shown on the computer screen. It is detecting the temperature of a waving hand, where the array clearly shows that it is hotter as the hand is detected and cooler when the hand is away from the camera. The PIR sensor also performed as expected, where motion and the length of time that the motion was detected was accurate. Powering it on was simple enough as there were only 3 pins on the sensor. The Piezo buzzer was also tested and functioning as expected. It was fairly simple to test this product since it just needed an input voltage and a ground. The sound output from it was considered great for the size and price of it.

The ATmega644P microchip also functioned as it should. It was able to successfully be powered on and programmed to show a blinking LED connected to one of its pins. One of the concerns with the microchip is that it doesn't have its own development board. This makes it more difficult to program since a developmental board is easier to handle and program. We are confident that we can overcome these difficulties with the microchip as code portability from the Arduino Uno development board is very similar for the ATmega644P microchip. There are also various online resources showing how to program each device with or without a development board. Overall, the team is confident that the Baby Buoy device will be a success, given that we each have different skills and specialties corresponding to specific parts of the device.

Appendix A References

- [1] PoolWarehouse. *cFloat pool alarm system*. Nov. 8, 2018. URL: <https://www.poolwarehouse.com/shop/cfloat-pool-alarm/>
- [2] Bonanza. *SafeFamilyLife pool alarm system*. Nov. 8, 2018. URL: https://www.bonanza.com/listings/Safe-Family-Life-Pool-Alarm-System/555576927?goog_pla=1&gpid=68416461421&keyword=&goog_pla=1&pos=1o5&ad_type=pla&gclid=Cj0KCKQiA_s7fBRDrARIsAGEvF8TuN0XxyP31nAJ6TGwZ-o1yUYZrccmWZ1qznBxMRGMVm1kCjq1PcsQaAtUwEALw_wcB
- [3] Adafruit Industries. *ESP8266*. Nov. 8, 2018. URL: <https://www.adafruit.com/product/2471>
- [4] Adafruit Industries. *ESP32*. Nov. 8, 2018. URL: <https://www.adafruit.com/product/3591>
- [5] Adafruit Industries. *ATWINC1500*. Nov. 8, 2018. URL: <https://www.adafruit.com/product/2999>
- [6] Digi-Key Electronics. *Piezo Buzzer*. Nov. 14, 2018. URL: https://www.digikey.com/product-detail/en/adafruit-industries-llc/1739/1528-1566-ND/5824413&?gclid=Cj0KCKQiA_s7fBRDrARIsAGEvF8TLAtHje7AQltVFMg2U6cEkvdmv3X4NqJvPY-zJ3KM86FqFOXBeqKgaAqkVEALw_wcB
- [7] MathWorks. *Image Processing Data Exhibition*. Nov. 8, 2018. URL: <https://www.mathworks.com/matlabcentral/fileexchange/28445-image-processing-laboratory?focused=5164990&tab=function>
- [8] Adafruit Industries. *PIR Sensor*. Nov. 8, 2018. URL: <https://www.adafruit.com/product/189>
- [9] Adafruit Industries. *AMG8833 Camera Module*. Nov. 8, 2018. URL: <https://www.adafruit.com/product/3538>
- [10] IPC . *IPC Standards*. Nov. 8, 2018. URL: <http://www.ipc.org/ContentPage.aspx?pageid=Why-Should-OEMs-Use-IPC-Standards>
- [11] Blue Sea Systems. *IP Rating Chart*. Nov. 8, 2018. URL: <https://www.blueseas.com/resources/117>
- [12] Adafruit Industries. *Cable Gland*. Nov. 20, 2018. URL: <https://www.adafruit.com/product/761>
- [13] Adafruit Industries. *5000mAh 3.7V Li-Po battery used*. Nov. 20, 2018. URL: <https://www.adafruit.com/product/1578>

[14] “How does a battery work?” by Mary Bates:
<https://engineering.mit.edu/engage/ask-an-engineer/how-does-a-battery-work/>

[15] “Different Types of Batteries and their Applications” by Odunlade Emmanuel:
<https://circuitdigest.com/article/different-types-of-batteries>

[16] “Li-Ion Battery Charging” by Pinomelean:
<https://www.instructables.com/id/Li-ion-battery-charging/>

[17] “How do Photovoltaics Work?” by Gil Knier
<https://science.nasa.gov/science-news/science-at-nasa/2002/solarcells>

[18] “PCB Basics” by SFUuptownMaker
<https://learn.sparkfun.com/tutorials/pcb-basics/all>

[19] “What is Pulse Width Modulation (PWM) Signal and What is it Used For?” by National Instruments:
<https://knowledge.ni.com/KnowledgeArticleDetails?id=kA00Z0000019OkFSAU>

Appendix B Permissions

 **Jones** <jones@poolwarehouse.com> 10:48 AM (1 minute ago) ☆ ↶ ⋮
to me ▾
Ok!

Thanks!

Jones

Pool Kit Sales Department
Email: jones@poolwarehouse.com
Phone: 800-515-1747 Ex. 1

From: <noreply@zqjim.com> on behalf of Zendesk Chat <noreply@zqjim.com>
Reply-To: Neysha Irizarry Cardoza <irizarry.neysha@gmail.com>
Date: Wednesday, November 7, 2018 at 10:49 PM
To: "jt@poolwarehouse.com" <jt@poolwarehouse.com>, <jones@poolwarehouse.com>
Subject: Offline Message from Neysha Irizarry Cardoza: Hello, I am a student at the Un

Offline Message from Neysha Irizarry Cardoza

Offline Message left on 08 Nov 2018, 03:49 AM (GMT+0)

Hello, I am a student at the University of Central Florida. I am currently working with a group on our Sr. Design Class to create a pool alarm. I am requesting permission to use your image from the following URL on my research paper <https://www.poolwarehouse.com/shop/cfloat-pool-alarm/> Thank You, Respectfully, -- Neysha Irizarry-Cardoza irizarry.neysha@gmail.com Cell : 407-733-5088

Figure 56: cFlout Permission Request



Natalie (Bonanza) <support@bonanza.zendesk.com>
to me ▾

Thu, Nov 8, 6:09 PM (12 days ago) ☆ ↶ ⋮

Hey Irizarry

Good news! An agent has reviewed your request and has provided an update, located below. Feel free to add a comment at any time by replying to this email.

Natalie (Bonanza)

Nov 8, 3:09 PM PST

Hello Irizarry,

Thanks for your email and welcome to **Bonanza**, an online marketplace connecting buyers and sellers directly where you can find everything but the ordinary in one of the friendliest communities on the internet!

Bonanza does not produce, house or ship any products, so if you have specific questions about an item you've located on **Bonanza**, you will want to contact the seller directly. On the item description page, you will see a "Send a message" button under the "Add to Cart" button. When you click the "Send a message" button, you will be able to enter a personalized message with any questions you have prior to completing your purchase.

You should be able to purchase an item or make an offer without a **Bonanza** account, but you will need to register with our site in order to seamlessly contact a seller. Registration at **Bonanza** is free and very quick; we only require your zip code, email address, and for you to create a username and password. Here is a link to do so: <https://www.bonanza.com/users/new>

To visit our buyer help pages: http://www.bonanza.com/site_help/offers

May you enjoy your experience at **Bonanza**, and please do not hesitate to ask any questions or let us know how we can be of further assistance.

Figure 57: SafeFamilyLife pool alarm system Permission

Re: [[Press/Media] > Inbox x



Adafruit Industries <support@adafruit.com>
to me ▾

Thu, Nov 15, 9:15 AM

that is all good! please do.

On Thu, Nov 15, 2018 at 8:44 AM Neysha Irizarry <support@adafruit.com> wrote:

contactname : Neysha Irizarry

email address : irizarry.neysha@gmail.com

message text : Hello,

I am a student at the University of Central Florida. I am currently working with a group on our Sr. Design Class to create a pool alarm. I am requesting permission to use your image from the following URL(s) on my research paper for illustration purposes:

-<https://www.adafruit.com/product/189>

-<https://www.adafruit.com/product/3538>

-<https://www.adafruit.com/product/3591>

-<https://www.adafruit.com/product/2471>

-<https://www.adafruit.com/product/2999>

Thank You,

Respectfully,

Neysha Irizarry

Client IP: 132.170.253.69

Figure 58: ESP32, ESP8266, ATWINC1500, PIR Sensor, AMG8833 Camera Module

PERMISSION AGREEMENT

This Permission Agreement (this "Agreement") is made and entered into this 14th day of November, 2018 ("Effective Date") by and between Digi-Key Electronics, a Minnesota corporation, 701 Brooks Avenue South, Thief River Falls, Minnesota 56701 USA ("Digi-Key"), and Neysha Irizarry ("Permitted User"). In consideration of the foregoing and of the mutual agreements, promises and covenants contained herein, the receipt and sufficiency of which are hereby acknowledged, the Corporation and the Vendor agree as follows:

1. Digi-Key hereby grants the Permitted Use the right to use the following image(s) and materials provided by Digi-Key Electronics:



https://www.digikey.com/product-detail/en/adafruit-industries-llc/1739/1528-1566-ND/5824413&?gclid=CjwKCAiArK_fBRABEiwAOgOOc7sP7ommxv3Rj1auaGXl7XDBKMaLeZXrfOp4XxURvHvuMWUP1ApXzBoCBcsQAvD_BwE

("Materials") to the extent that Digi-Key has rights in the Materials.

2. The limited scope of the permitted use is as follows: Sr. Design Class research paper for pool alarm creation ("Permitted Use")

3. The Permitted User shall make no use of the Materials beyond the scope of the Permitted Use.

4. Digi-Key grants its permission to the Materials AS IS and EXPRESSLY DISCLAIMS ALL WARRANTIES OF ANY KIND, EXPRESS, IMPLIED, STATUTORY OR OTHERWISE, INCLUDING, BUT NOT LIMITED TO, IMPLIED WARRANTIES OF MERCHANTABILITY, FITNESS FOR A PARTICULAR PURPOSE, AND NONINFRINGEMENT WITH REGARD TO THE MATERIALS. Digi-Key shall have no liability to Permitted User relating to Permitted User's use of the Materials. To the maximum extent permitted by law, the Permitted User shall defend, indemnify and hold harmless Digi-Key and its related and affiliated companies and all divestitures, directors, officers, employees, and agents and hold them harmless from all obligations, costs, fees, losses, liabilities, claims, judgments, actions, damages and expenses, including reasonable attorneys fees, suffered, incurred or sustained by Digi-Key, its related and affiliated companies and all their respective directors, officers and employees which arise out of or are related to your use of the Materials.

5. This Agreement is subject to the Terms and Conditions found at the Digi-Key web site (www.digikey.com), and they are hereby made a part of this Agreement, except as expressly modified by Section 2 of this Agreement regarding the permitted scope of use of the Materials, which modifies paragraph 2 of the web site Terms and Conditions.

DIGI-KEY ELECTRONICS

PERMITTED USER

By Cory Helm
(Signature)

By Neysha Irizarry C
(Signature)

Name Cory Helm
(Printed)

Name Neysha Irizarry Cardoza
(Printed)

Its Team Lead, MKTG Production
(Title)

Address: 609 Wren Avenue Longwood FL 32750
(Address)

Figure 59: Piezo Buzzer Permission

Deployment Rights for User Files

You may distribute or sublicense User Files without restriction, provided that a principal purpose of the distribution or sublicense is not to replace or replicate a Program or any part of a Program and you otherwise comply with the general restrictions of the Software License Agreement and your License Offering. "User Files" are MATLAB code files, Simulink model files, MEX-files, MAT-files, VHDL-files, Verilog-files, FIG-files or P-files that you create and that do not include any code obtained from MATLAB code files, Simulink model files, MAT-files, VHDL-files, Verilog-files, TLC-files, P-code, C/C++ files or other Source Code files supplied with the Programs.

Figure 60: Image Processing Data Exhibition User Rights

Copyright Permission Inbox x

 **Neysha Irizarry** Nov 20, 2018, 8:55 PM (6 days ago) ☆
Hello, I am a student at the University of Central Florida. I am currently working with a group on our Sr. Design Class to create a pool alarm. I am requesting

 **IPC Marketing** 10:08 AM (14 minutes ago) ☆ ↶ ⋮
to me ▾

Hi Neysha
Please use the attached as it is the most recent image.
Also, please indicate in your paper "used by permission of IPC 2018"

Michael D. Milostan (Mike)
Marketing Director, Standards, Technology and Certification
IPC
3000 Lakeside Drive
Suite 105 N
Bannockburn, IL 60015
Direct: 847-597-2812

From: Neysha Irizarry <irizarry.neysha@gmail.com>
Sent: Tuesday, November 20, 2018 7:56 PM
To: IPC Marketing <IPCMarketing@ipc.org>
Subject: Copyright Permission

⋮

Figure 61: IPC Standards Permission

Copyright Permission



Neysha Irizarry <irizarry.neysha@gmail.com>
to conductor

Tue, Nov 20, 8:59 PM (13 hours ago) ☆ ↶ ⋮

Hello, I am a student at the University of Central Florida. I am currently working with a group on our Sr. Design Class to create a pool alarm. I am requesting permission to use your image from the following URL on my research paper for illustration purposes:

<https://www.bluesea.com/resources/117>

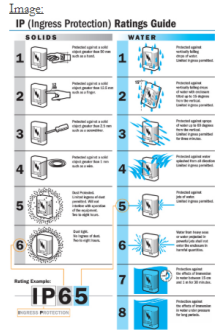

Thank You,
Regards,

Figure 62: IP Rating Chart Permission



Adafruit Industries

to me ▾

8:44 PM (0 minutes ago) ☆

yep, totally OK please do.

On Tue, Nov 20, 2018 at 8:44 PM Neysha Irizarry <support@adafruit.com> wrote:

contactname : Neysha Irizarry

email address : irizarry.neysha@gmail.com

message text : Hello,

I am a student at the University of Central Florida. I am currently working with a group on our Sr. Design Class to create a pool alarm. I am requesting permission to use your image from the following URL on my research paper for illustration purposes:

<https://www.adafruit.com/product/1578>

<https://www.adafruit.com/product/761>

Thank You,

Regards,

Neysha Irizarry C.

Client IP: 68.204.28.230

Figure 63: Cable Gland, 5000mAh 3.7V Li-Po battery used Permission